

Smart performance with innovative and ever-strong coil drive even under harsh working environments



Features

- ▶ Easy and quick auto-calibration
- ▶ Detecting RA (reverse acting) or DA (direct acting) automatically regardless of wrong air connections
- ▶ Available to use for single or double acting without any special adjustments
- ▶ Compact design allowing to be installed on small actuators
- ▶ Providing error messages against performance failures
- ▶ Possible to test the actuator with any fixed signal under a test mode
- ▶ Programmable characteristic curve with 17 points
- ▶ Wide operating temperature range -30 ~ +80 °C
- ▶ Improved control of high-friction globe and ball valves by eliminating an overshoot and a hunting
- ▶ Low air consumption
- ▶ Providing a mounting bracket to meet IEC 60534-6-1 for linear valves
- ▶ Supporting a NAMUR mounting pattern VDI/VDE 3845 (IEC 60534-6-2) and providing a multi-size mounting bracket for rotary valves

Options

- ▶ Output position transmitter (4 - 20 mA)
- ▶ 2 x alarm limit or micro switch (SPDT)
- ▶ Low temperature (- 40°C)
- ▶ Intrinsically safe type (IECEX / ATEX / TR-CU / KC Ex ia IIC T6/T5)
- ▶ HART communication
- ▶ Profibus PA communication
- ▶ Foundation Fieldbus communication

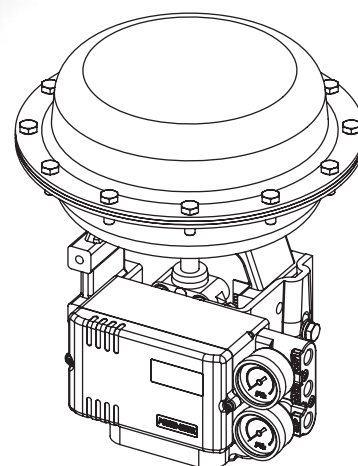

- SS2L (Linear Type)

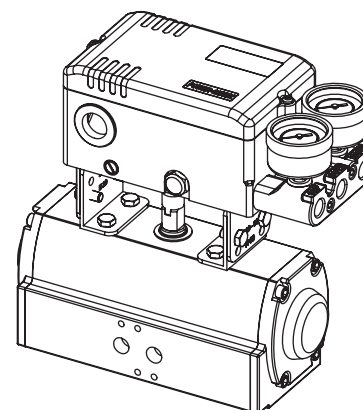

- SS2R (Rotary Type)

Specifications

Communication	Without	HART	Profibus - PA	Foundation Fieldbus
Input Signal / Bus voltage	4 - 20 mA @ 24 VDC		9 - 32 VDC	
Min. / Max. Current	3.6 mA / 50 mA		-	
Current Consumption	-		15mA	16mA
Voltage Drop (Resistance)	8.7 VDC(435Ω)	9.4 VDC(470Ω)	-	
Stroke / Angle	Linear type : 5 - 130 mm * Rotary type : 25 - 120°			
Air Supply Pressure	1.4 - 7.0 bar (20 - 100 psi), filtered, compressed dry and non-oiled to meet Class 3 of ISO 8573-1			
Output Pressure Range	0 - 100% of supply air pressure			
Air Capacity	80 l/min = 4.8 N ^m /h = 2.8 scfm (Sup = 1.4 bar) 233 l/min = 14 N ^m /h = 8.2 scfm (Sup = 6 bar)			
Air Consumption	2.8 l/min = 0.17 N ^m /h = 0.1 scfm (Sup = 1.4 ~ 6 bar)			
Characteristic	Linearity < ±0.3% F.S Hysteresis < 0.2% F.S		Sensitivity < 0.2% F.S Repeatability < 0.2% F.S	
Performance Characteristic	Linear, EQ %, Quick open, User set (17 points)			
LCD Indication	4-digit LCD indicator			
Adjustable Speed	1 - 1000 (lowest 1, highest 1000)			
Scan Time	2ms			
Shut-off Value	Range 0 - 10% of position signal			
Valve Action	direct action (DA) / reverse action (RA)			
Operating Temperature	- 30 ~ +80 °C (- 22 ~ +176 °F) **			
Pneumatic Connections	PT(Rc) 1/4 or NPT 1/4			
Electrical Connections	2 x PF(G) 1/2 , NPT 1/2 , M20 x 1.5			
Protection Class	IP66, Intrinsically safe (IECEX / ATEX / KC Ex ia IIC T6/T5)			
Body Material	Aluminum die-cast / powder-painted			
Weight	1.6 kg			

* Up to 200mm on request ** -40 °C on request

Principle of Operation

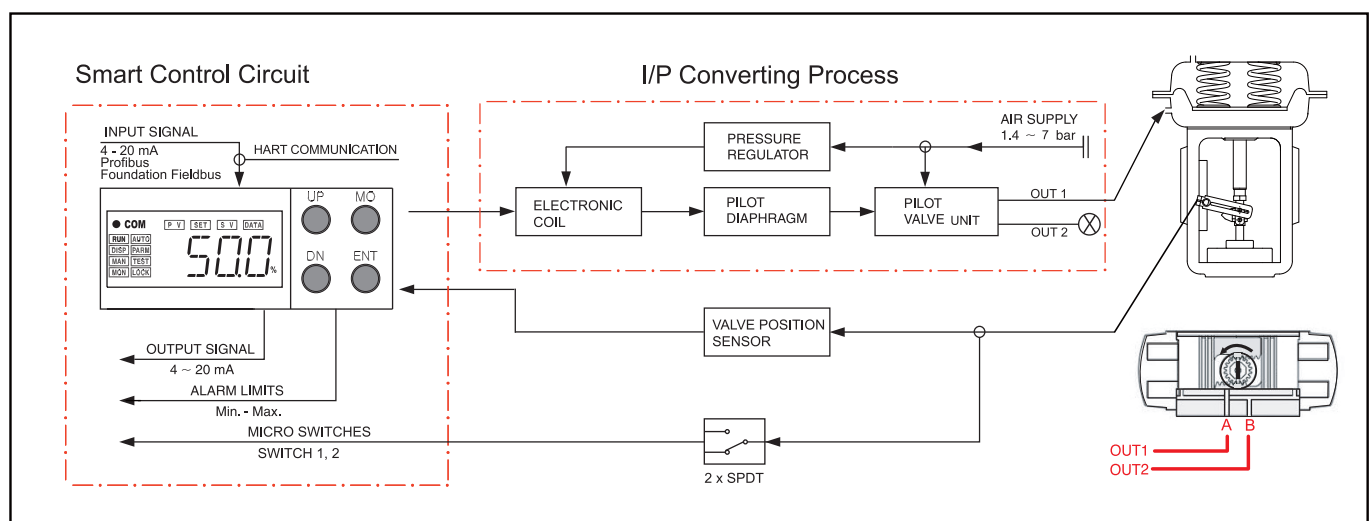

If 4-20 mA input signal(or Bus communication signal) is supplied, the micro processor compares input signal with position feedback and sends control signal to the I/P converting module. Pneumatic signal from the I/P converting module operates the valve and the valve stays at the desired position.

Mounting to Linear Actuator

- SS2L (Linear Type)

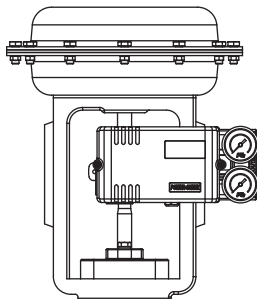

< Front View >

OUT1
OUT2
SUP



< Side View >

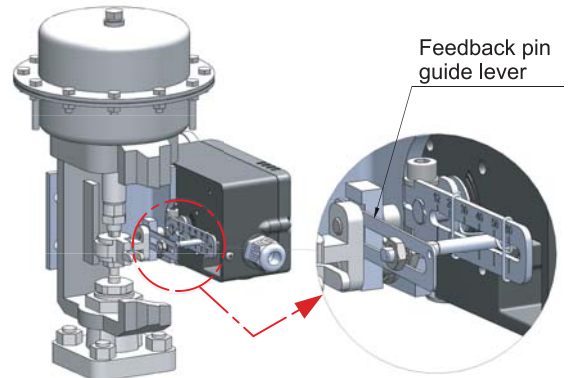

< Feedback Lever Connection >

"A" Type

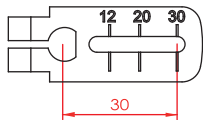

"B" Type

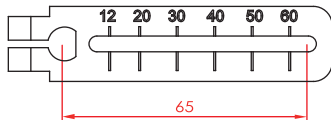

"C" Type

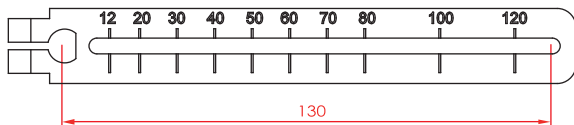

Feedback Lever

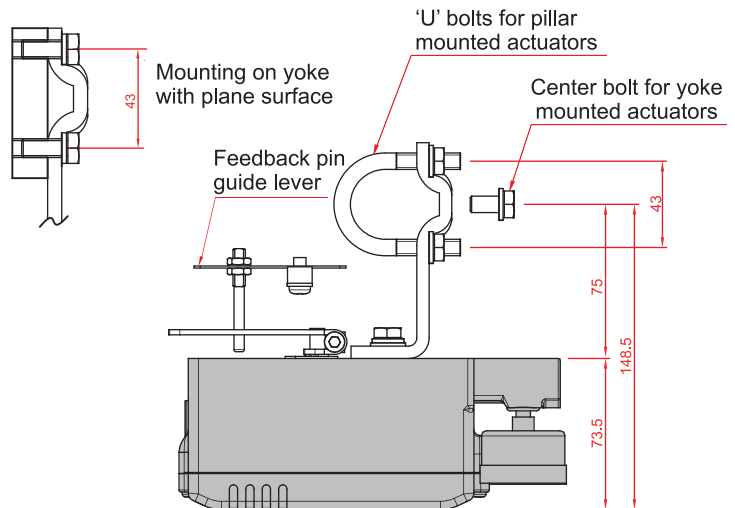

Mounting to linear actuators to IEC 60534 6-1

Mounting to Rotary Actuator

- SS2R (Rotary Type)

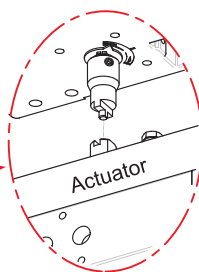
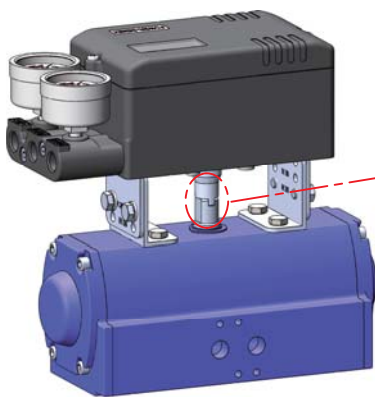

NAMUR Type Mounting
(VDI/VDE 3845,
IEC 60534-6-2)

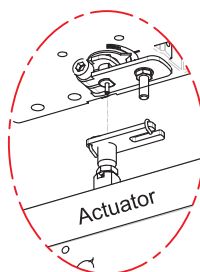

Fork Lever Type Mounting

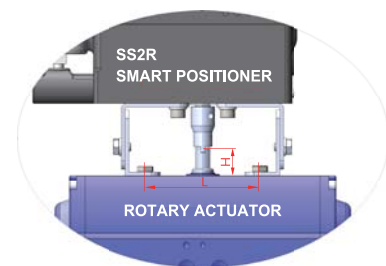

Size Variation of Multi-Size Bracket

- 1) 80 x 30 x 20 (H) , 4) 130 x 30 x 20 (H)
- 2) 80 x 30 x 30 (H) , 5) 130 x 30 x 30 (H)
- 3) 80 x 30 x 50 (H) , 6) 130 x 30 x 50 (H)

H : Rotary Actuator Shaft Height
L : Length (80 or 130mm)

Air Connections

- SS2L (Linear Type)

Direct Acting (DA)		Reverse Acting (RA)	
<p>DA 1</p> <p>As the input signal increases, Valve stem moves downwards</p> <p>Actuator : DA</p>	<p>OUT2 must be plugged</p>	<p>RA 1</p> <p>As the input signal increases, Valve stem moves upwards</p> <p>Actuator : RA</p>	<p>OUT2 must be plugged</p>
<p>DA 2</p> <p>As the input signal increases, Valve stem moves downwards</p> <p>Actuator : DA</p>	<p>OUT1 must be plugged</p>	<p>RA 2</p> <p>As the input signal increases, Valve stem moves upwards</p> <p>Actuator : RA</p>	<p>OUT1 must be plugged</p>
<p>DA 3</p> <p>As the input signal increases, Valve stem moves downwards</p>		<p>RA 3</p> <p>As the input signal increases, Valve stem moves upwards</p>	

- SS2R (Rotary Type)

Spring Return	Double Acting	Double Acting
<p>Actuator : RA</p> <p>OUT2 must be plugged</p>	<p>Actuator : RA</p>	<p>Actuator : DA</p>
<p>As the input signal increases, Actuator shaft rotates counter-clockwise</p>	<p>As the input signal increases, Actuator shaft rotates counter-clockwise</p>	<p>As the input signal increases, Actuator shaft rotates clockwise</p>

	Spring Return	Double Acting
Reverse Acting	Out 1 : piped, Out2 : plugged	Out 1 : piped to Actuator port A, Out2 : piped to Actuator port B
Direct Acting	Out 1 : plugged, Out 2 : piped	Out 1 : piped to Actuator port B, Out 2 : piped to Actuator port A

SS2 Front Cover Removed

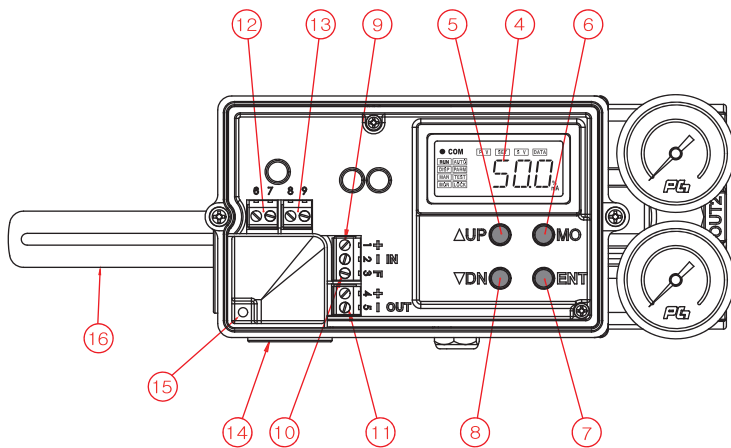

- 1 : Air supply
- 2 : OUT 1
- 3 : OUT 2
- 4 : Display LCD
- 5 : Up key
- 6 : Mode key
- 7 : Enter key
- 8 : Down key
- 9 : Input signal (+, -)
- 10 : Frame ground
- 11 : Output signal (+, -)
- 12 : Alarm limit 1
- 13 : Alarm limit 2
- 14 : Electrical connections
- 15 : Ground
- 16 : Feedback lever

Electrical Connections

- 1 (+) } IN. 4-20mA input signal
- 2 (-) }
- 3 (FG) } Frame Ground
- 4 (+) } OUT. 4-20mA output signal
- 5 (-) }
- 6 (+) } LS1. (Low) Alarm limit 1
- 7 (-) }
- 8 (+) } LS2. (High) Alarm limit 2
- 9 (-) }

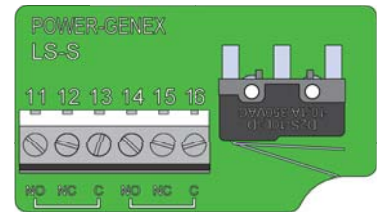
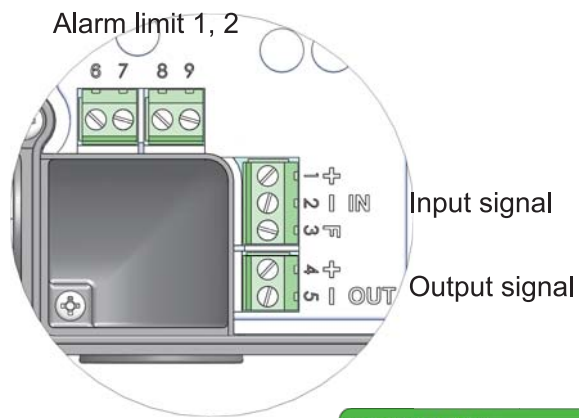

Micro switches 1, 2

Characteristic Curves

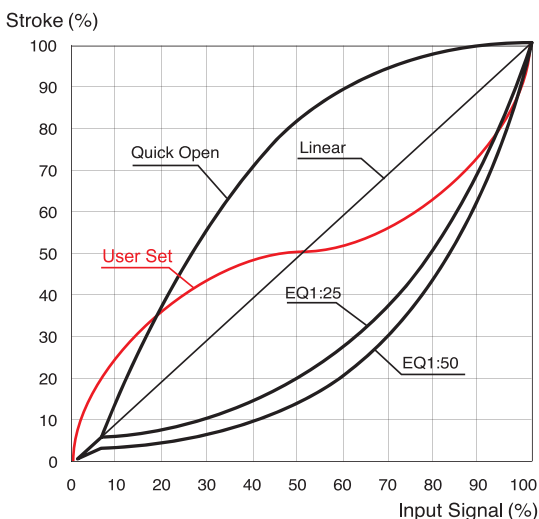

Quick Start and Checking

	Button	Action
Auto - Calibration	MO	Push 5 seconds for auto-calibration
Span	VDN → ENT or VDN → ΔUP ENT → MO	Push VDN 5 seconds to change a measured span (Try this option only when a valve doesn't reach a desired position)
Ambient Temp.	ENT	Confirm an ambient temperature surrounding this smart valve positioner

Parameters Diagram

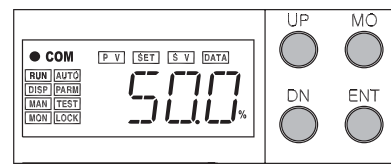
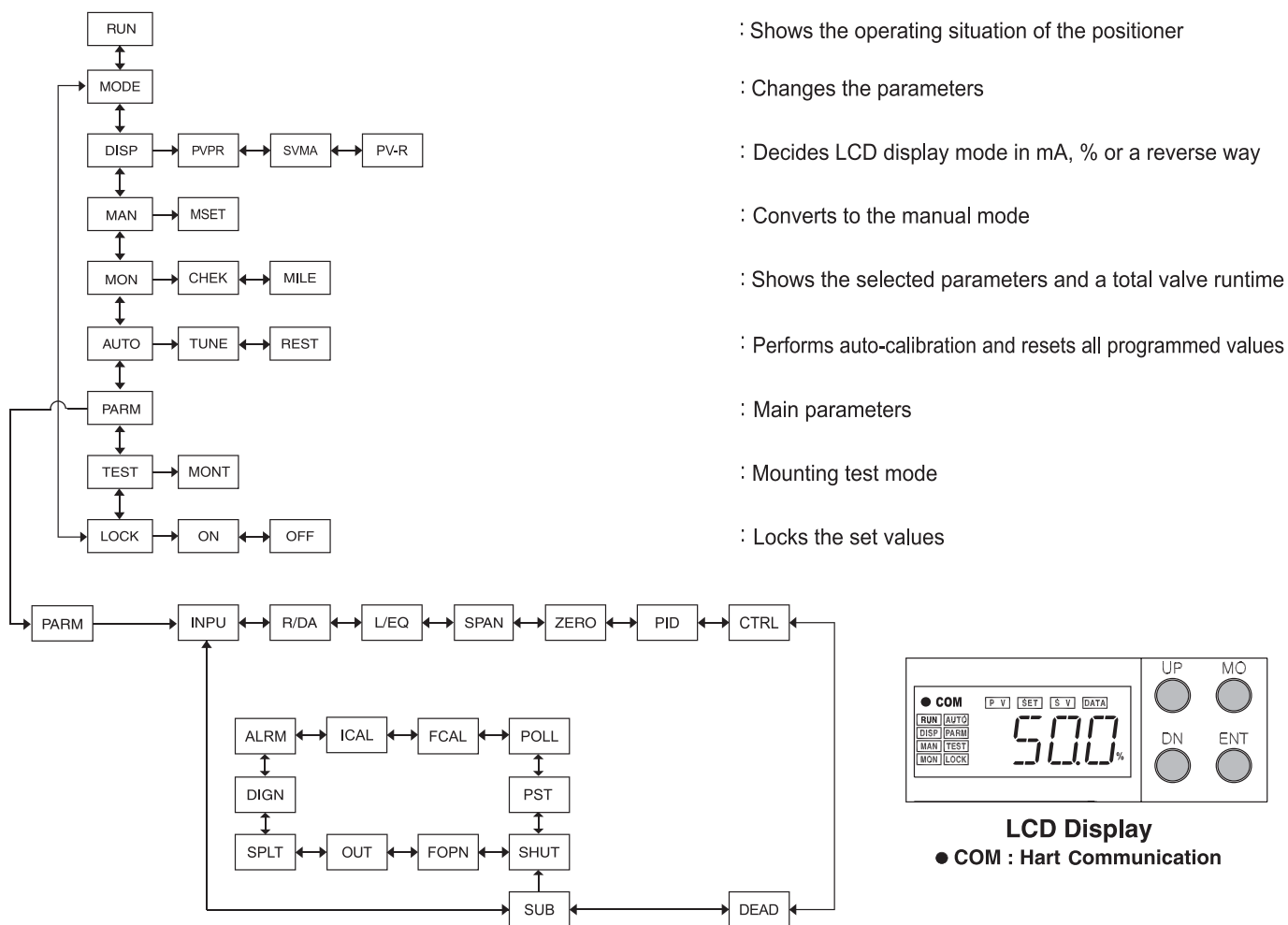

LCD Display

● COM : Hart Communication

Parameter	Description	Fcution	Default
INPU	Input signal	4 ~ 20mA or 20 ~ 4mA	4 ~ 20mA
R/DA	RA/DA	Reverse acting or direct acting	Auto-set
L/EQ	Characteristic	Linear, E.Q.%(1:25 or 1:50), Quick open or User set(17points)	Linear
SPAN	Span adjustment	0 ~ 100%	100%
ZERO	Zero adjustment	0 ~ 99%	0%
PID	P-GN / I-GN / D-GN	Proportional / Integral / Differential gain value	Auto-set
SPED	Response speed	1 ~ 1000	1000
SWST	Slow start	Smooth operation (ON or OFF)	Auto-set
CNLT	Control limit	50 ~ 1250	Auto-set
GCNL	Gap control limit	50 ~ 1250	Auto-set
DEAD	Dead band	0 ~ 9.99%	0.5%
HDGP	D-gain setting for hard mode	D-Gain setting for hard mode	Auto-set
SHUT	Shut-off	0 ~ 9.9%	0.3%
FOPN	Full-open	0 ~ 9.9%	0.3%
OUT	Output signal	4 ~ 20mA or 20 ~ 4mA	4 ~ 20mA
SPLT	Split range	4 ~ 12mA or 12 ~ 20mA	4 ~ 20mA
DIGN	Display place	Movement to one or two decimal places	1
ALAM	Alarm limit low, high	AL1L / AL1H / AL2L / AL2H	0 ~ 10%, 90 ~ 105%
ICAL	IN4M / IN20	Internal match with 4~20mA input signals from a calibrator	Factory setting
FCAL	FB4M / FB20	Internal match with 4~20mA output signals to a calibrator	Factory setting
POLL	Polling address	HART Communication polling address (0 ~ 15)	0
PST	Partial stroke test	Checks a valve status	OFF

Wiring Alarm Limits

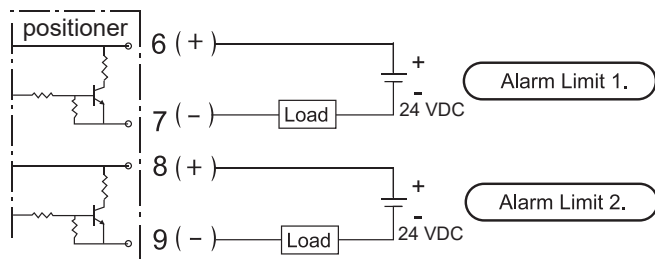

Note that 24 VDC should be supplied for power.

Micro Switches (SPDT)

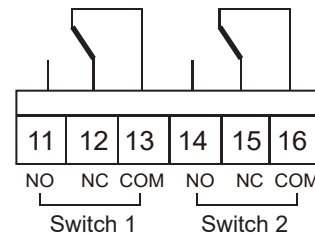

Measuring Output Signal

① With mA loop calibrator

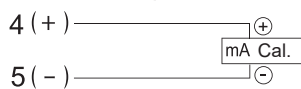

② With multimeter (mA)

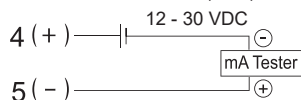

ZERO and SPAN of position feedback are automatically set after auto-calibration process.

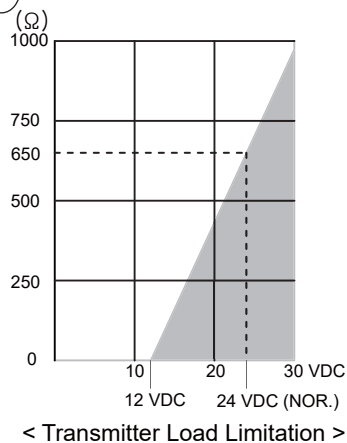

Micro Switches

Type	SPDT
Rating	10.1A @ 250 VAC
Ambient Temperature	-30 ~ +85°C
Position Transmitter	
Output Signal	4 - 20 mA, 2-wire
Power Supply	12 - 30 VDC
Output Current Limit	30 mA DC
Linearity	1% F.S
Operating Temperature	-40 ~ +80°C

How to Order

SS2

Actuator Operation	Protection Class	Feedback Lever	Pressure Gauges	By-pass	Position Feedback	Communication	Connection Threads	Mounting Bracket	Feedback Pin Guide Lever Set
--------------------	------------------	----------------	-----------------	---------	-------------------	---------------	--------------------	------------------	------------------------------

Description	Code
Actuator Operation :	L : Linear type R : Rotary type
Protection Class :	I : Intrinsically safe IECEX / ATEX / TR-CU Ex ia IIC T6/T5 K : Intrinsically safe KC - Ex ia IIC T6/T5 W : Weatherproof to IP66
Feedback Lever :	
- Linear type :	A : Stroke (5-30mm) B : Stroke (5-65mm) C : Stroke (5-130mm) D : Stroke (80-200mm)
- Rotary type :	F : Fork lever N : NAMUR shaft (direct mounting)
Gauge Block :	0 : Not mounted 1 : 6 bar (90 psi) 2 : 10 bar (150 psi)
By-pass :	N : None (standard) Y : Yes (auto/manual screw)

Description	Code
Position Feedback :	N : None O : Position transmitter (4-20mA output signal) L : 2 x alarm limit S : 2 x micro switch (SPDT) M : O + L Q : O + S
Communication : (only for weatherproof type)	N : None H : HART P : Profibus PA F : Foundation Fieldbus
Connection Threads : (pneumatic - electrical)	3 : PT(Rc) 1/4 - PF(G) 1/2 4 : NPT 1/4 - NPT 1/2 5 : PT(Rc) 1/4 - M20 x 1.5
Mounting Bracket :	N : None L : IEC 60534-6-1 (for SS2L) R : IEC 60534-6-2 (for SS2R) VDI/VDE 3845
Feedback Pin Guide Lever Set : (only for linear type SS2L)	0 : Not included 1 : Included

Dimensions

- SS2L (Linear Type)

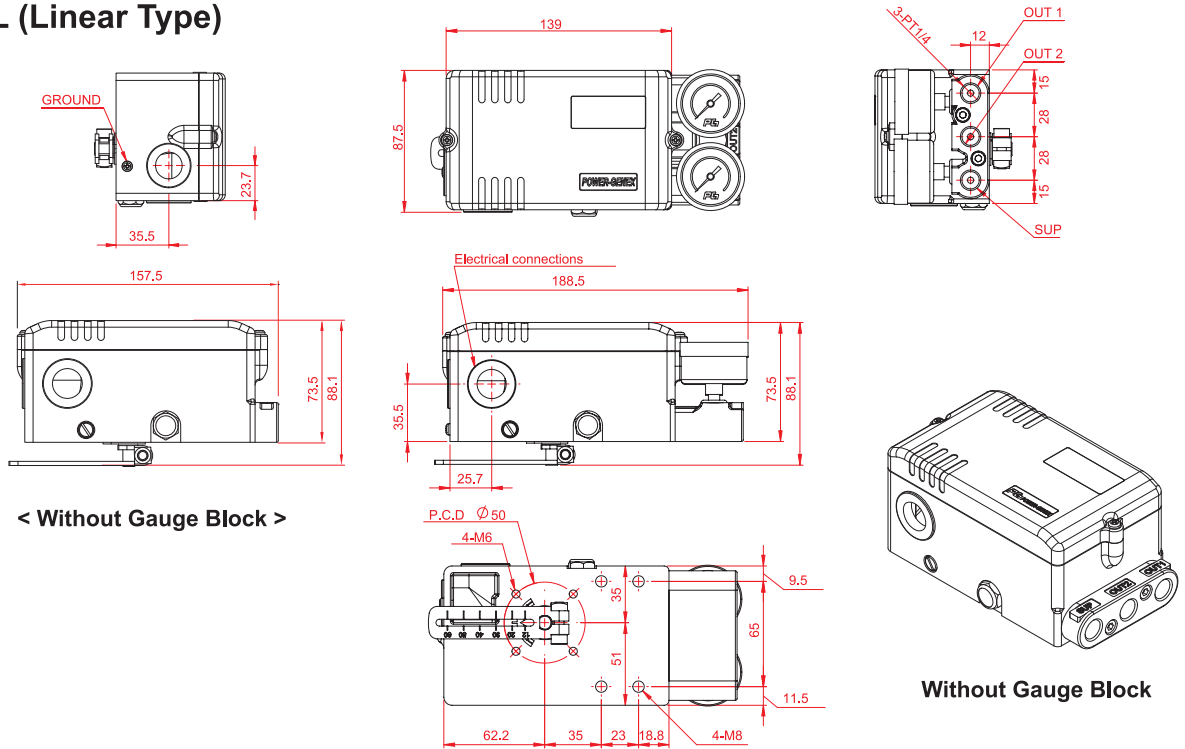

- SS2R (Rotary Type)

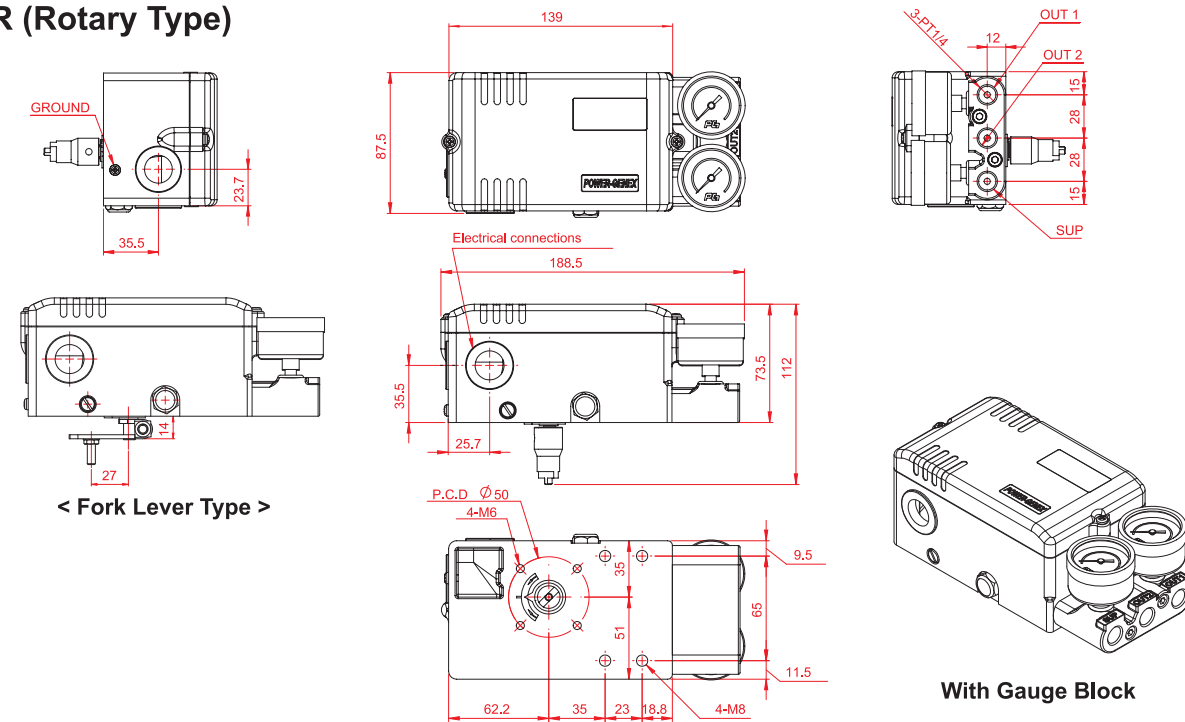

- SS2 with 2 x SPDT Micro S/W

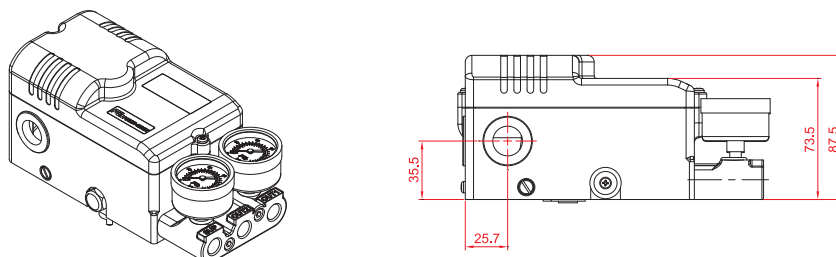



< SS2SL & SS2SR >

Specifications

Communication	Without	HART	Profibus-PA	Fieldbus
Input Signal	4 - 20 mA @ 24 VDC		9 - 32 VDC	
Min. / Max. Current	3.6 mA / 50 mA		-	
Current Consumption	-		15mA	16mA
Voltage Drop (Resistance)	8.7 VDC(435Ω)	9.4 VDC(470Ω)		
Stroke / Angle	Linear type : 5 - 130 mm * Rotary type : 25 - 120°			
Air Supply Pressure	1.4 - 7.0 bar (20 - 100 psi)			
Output Pressure Range	0 - 100% of supply air pressure			
Air Capacity	80 l/min = 4.8 N ^m /h = 2.8 scfm (Sup = 1.4 bar) 233 l/min = 14 N ^m /h = 8.2 scfm (Sup = 6 bar)			
Air Consumption	2.8 l/min = 0.17 N ^m /h = 0.1 scfm (Sup = 1.4 ~ 6 bar)			
Characteristic	Linearity < ±0.3% F.S Hysteresis < 0.2% F.S		Sensitivity < 0.2% F.S Repeatability < 0.2% F.S	
Performance Characteristic	Linear, EQ %, Quick open, User set (17 points)			
LCD Indication	4-digit LCD indicator			
Adjustable Speed	1 - 1000 (lowest 1, highest 1000)			
Scan Time	2ms			
Shut-off Value	Range 0 - 10% of position signal			
Valve Action	Direct action(DA) / Reverse action(RA)			
Operating Temperature	- 30 ~ +80 °C (- 22 ~ +176 °F) **			
Pneumatic Connections	NPT 1/4 (other on request)			
Electrical Connections	NPT 1/2 (other on request)			
Protection Class	IP66, Intrinsically safe (IECEX / ATEX / KC Exia IIC T6/T5)			
Body Material	Stainless steel 316			
Weight	3.8 kg (without bracket)			



How to Order

* Up to 200mm on request ** -40°C on request

SS2S

Actuator Operation	Protection Class	Feedback Lever	Pressure Gauges	By-pass	Position Feedback	Communication	Connection Threads	Mounting Bracket	Feedback Pin Guide Lever Set
--------------------	------------------	----------------	-----------------	---------	-------------------	---------------	--------------------	------------------	------------------------------

Description	Code
Actuator Operation :	L : Linear type R : Rotary type
Protection Class :	I : Intrinsically safe IECEX / ATEX / TR-CU Ex ia IIC T6/T5 K : Intrinsically safe KC - Ex ia IIC T6/T5 W : Weatherproof to IP66
Feedback Lever :	
- Linear type :	A : Stroke (5-30mm) B : Stroke (5-65mm) C : Stroke (5-130mm) D : Stroke (80-200mm)
- Rotary type :	F : Fork lever N : NAMUR shaft (direct mounting)
Gauge Block :	0 : Not mounted 1 : 6 bar (90 psi) 2 : 10 bar (150 psi)
By-pass :	N : None Y : Yes (auto/manual screw)

Description	Code
Position Feedback :	N : None O : Position transmitter (4-20mA output signal) L : 2 x alarm limit S : 2 x micro switch (SPDT) M : O + L Q : O + S
Communication : (only for weatherproof type)	N : None H : HART P : Profibus PA F : Fieldbus Foundation
Connection Threads : (pneumatic - electrical)	4 : NPT 1/4 - NPT 1/2
Mounting Bracket :	N : None L : IEC 60534-6-1 (for SS2SL) R : IEC 60534-6-2 (for SS2SR) VDI/VDE 3845
Feedback Pin Guide Lever Set : (only for linear type SS2SL)	0 : Not included 1 : Included