

**Perfect combination with reliable fail freeze function and smart performance with innovative durable coil drive**

**FAIL  
FREEZE**



## Features

- ▶ “Fail Freeze” function to help the valve stay at the last position on the electrical power supply or the pneumatic supply air by accident
- ▶ Easy and quick auto-calibration
- ▶ Detecting RA (reverse acting) or DA (direct acting) automatically regardless of wrong air connections
- ▶ Available to use for single or double acting without any special adjustments
- ▶ Compact design allowing to be installed on small actuators
- ▶ Providing error messages against performance failures
- ▶ Possible to test the actuator with any fixed signal under a test mode
- ▶ Programmable characteristic curve with 17 points
- ▶ Wide operating temperature range -30 ~ +80 °C
- ▶ Improved control of high-friction globe and ball valves by eliminating an overshoot and a hunting
- ▶ Low air consumption
- ▶ Providing a mounting bracket to meet IEC 60534-6-1 for linear valves
- ▶ Supporting a NAMUR mounting pattern VDI/VDE 3845 (IEC 60534-6-2) and providing a multi-size mounting bracket for rotary valves

## Options

- ▶ Output position transmitter (4 - 20 mA)
- ▶ 2 x alarm limit or micro switch (SPDT)
- ▶ Explosion proof type (IECEX / ATEX / KC Ex ia IIC T6/T5 - in progress)
- ▶ HART communication
- ▶ Profibus communication (in progress)
- ▶ Fieldbus Foundation communication (in progress)

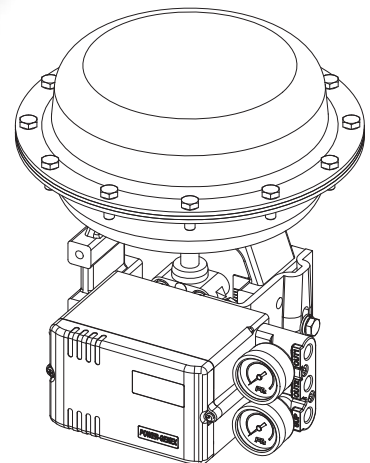

**- SS5L (Linear Type)**

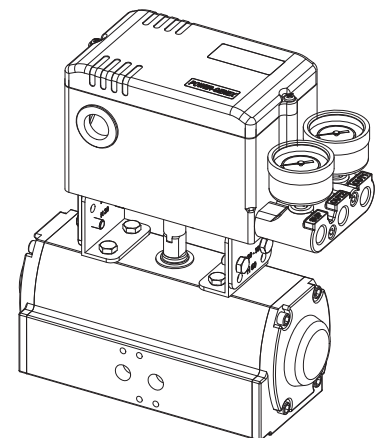

**- SS5R (Rotary Type)**

## Specifications

Input Signal	4 - 20 mA @ 24 VDC
Min. / Max. Current	3.6 mA / 50 mA
Voltage Drop (Resistance)	Without Hart : 8.9 VDC (445Ω @ 20 mA) With Hart : 9.4 VDC (470Ω @ 20 mA)
Stroke / Angle	Linear type : 5 - 130 mm * Rotary type : 25 - 120°
Air Supply Pressure	1.4 - 7 bar (20 - 100 psi), filtered, compressed dry and non-oiled to meet Class 3 of ISO 8573-1
Output Pressure Range	0 - 100% of supply air pressure
Air Capacity	80 ℓ/min = 4.8 N <sup>m</sup> /h = 2.8 scfm (Sup = 1.4 bar) 233 ℓ/min = 14 N <sup>m</sup> /h = 8.2 scfm (Sup = 6 bar)
Air Consumption	2 ℓ/min = 0.12 N <sup>m</sup> /h = 0.07 scfm (Sup = 1.4 ~ 6 bar)
Characteristic	Linearity < ±0.3% F.S      Sensitivity < 0.2% F.S Hysteresis < 0.2% F.S      Repeatability < 0.2% F.S
Performance Characteristic	Linear, EQ %, Quick open, User set (17 points)
LCD Indication	4-digit LCD indicator
Adjustable Speed	1 - 1000 (lowest 1, highest 1000)
Scan Time	2ms
Shut-off Value	Range 0 - 10% of position signal
Valve Action	Direct action (DA) / Reverse action (RA)
Operating Temperature	- 30 ~ +80 °C (- 22 ~ +176 °F) **
Pneumatic Connections	PT(Rc) 1/4 or NPT 1/4
Electrical Connections	2 x PF(G) 1/2, NPT 1/2, M20 x 1.5
Protection Class	IP66, intrinsically safe (IECEX / ATEX / KC Exia IIC T6/T5)
Body Material	Aluminum die-cast / powder-painted
Weight	1.6 kg

\* Up to 200mm on request      \*\* -40 °C on request

## Principle of Operation

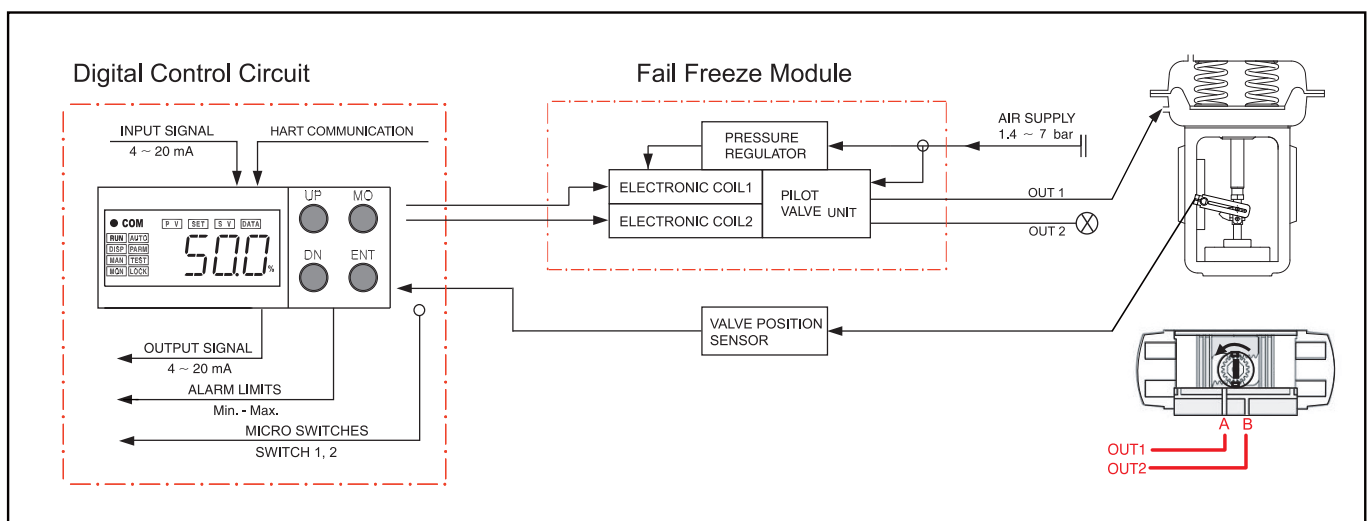

If 4-20mA input signal is supplied, the microprocessor compares the input signals and the feedback values and send the control signals to the I/P converter. A supply air is converted to the pneumatic signals by two electronic coils and moves the pilot valve until the control valve reaches the desired position. In case of a signal failure or a supply air failure, a venting air is blocked inside of the pilot valve and the valve stays at the last position because of an existing supply air pressure between the positioner and the actuator.

# Smart Valve Positioner ( fail freeze function )

# SS5 Linear / Rotary

## SS5 Front Cover Removed

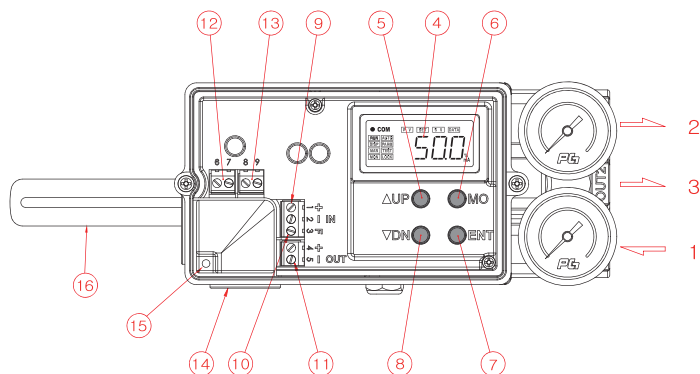

- 1 : Air supply
- 2 : OUT 1
- 3 : OUT 2
- 4 : Display LCD
- 5 : Up key
- 6 : Mode key
- 7 : Enter key
- 8 : Down key
- 9 : Input signal (+, -)
- 10 : Frame ground
- 11 : Output signal (+, -)
- 12 : Alarm limit 1
- 13 : Alarm limit 2
- 14 : Electrical connections
- 15 : Ground
- 16 : Feedback lever

## Electrical Connections

- 1 (+) → IN. 4-20mA input signal
- 2 (-) → Frame Ground
- 3 (FG) → Frame Ground
- 4 (+) → OUT. 4-20mA output signal
- 5 (-) → OUT. 4-20mA output signal
- 6 (+) → LS1. (Low) Alarm limit 1
- 7 (-) → LS1. (Low) Alarm limit 1
- 8 (+) → LS2. (High) Alarm limit 2
- 9 (-) → LS2. (High) Alarm limit 2

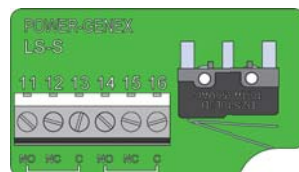
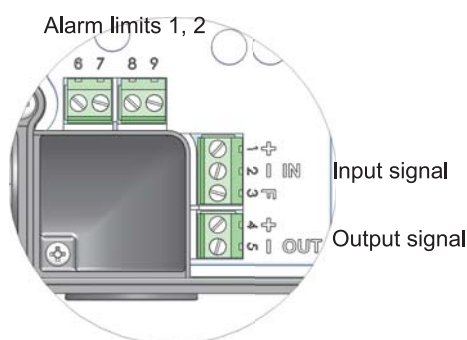

Micro switches 1, 2

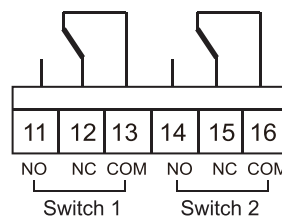

## How to Order

# SS5

- Actuator Operation
- Protection Class
- Feedback Lever
- Pressure Gauges
- Position Feedback
- Communication
- Connection Threads
- Mounting Bracket
- Feedback Pin Guide Lever Set

Description	Code
<b>Actuator Operation :</b>	L : Linear type R : Rotary type
<b>Protection Class :</b>	I : Intrinsically safe (IECEX Ex ia IIC T6/T5, ATEX Ex ia IIC T6/T5) K : Intrinsically safe (KC Ex ia IIC T6/T5) W: Weatherproof to IP66
<b>Feedback Lever :</b> - Linear Type	A : Stroke (5 ~ 30mm) B : Stroke (5 ~ 65mm) C : Stroke (5 ~ 130mm) D : Stroke (80 ~ 200mm)
- Rotary Type	F : Fork lever N : Namur shaft (direct mounting)
<b>Pressure Gauge Block :</b>	0 : Not mounted 1 : 6 bar (90 psi) 2 : 10 bar (150 psi)

Description	Code
<b>Position Feedback :</b>	N : None O : Position transmitter (4 ~ 20mA output signal) L : 2 x alarm limit S : 2 x micro switch (SPDT) M : O+L Q : O+S
<b>Communication :</b>	N : None H : HART
<b>Connection Threads :</b> (pneumatic - electrical)	3 : PT(Rc) 1/4 – PF(G)1/2 4 : NPT 1/4 – NPT 1/2 5 : PT(Rc) 1/4 – M20 x 1.5
<b>Mounting Bracket :</b>	N : None L : IEC 60534-6-1 (for SS5L) R : VDI/VDE 3845 / IEC 60534-6-2 (for SS5R)
<b>Feedback Pin Guide Lever Set :</b> (only for linear type SS5L)	0 : Not included 1 : Included

## Dimensions

### - SS5L (Linear Type)

Electrical connections  
2 - PF(NPT)1/2

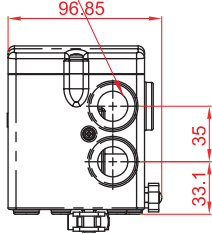

Electrical connections  
PF(NPT)1/2

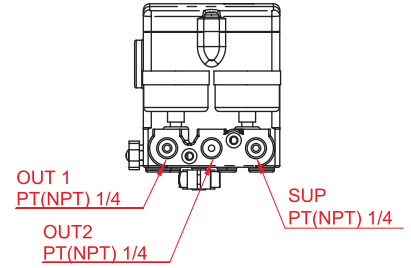
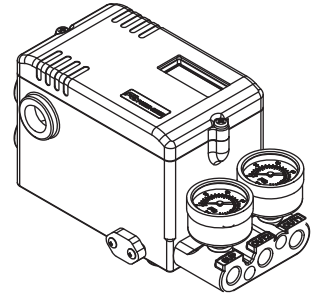
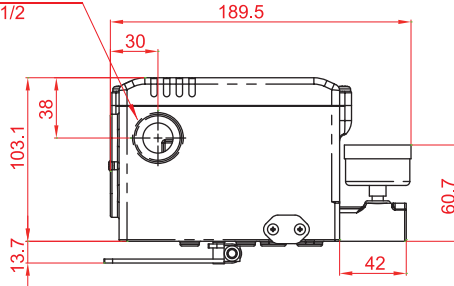

A,B,C,D TYPE LEVER

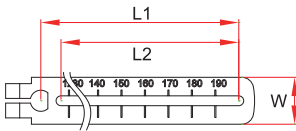

LEVER TYPE	L1(mm)	L2(mm)	W(mm)
A	30	21.40	20
B	65	55.90	20
C	130	121.40	20
D	200	191.40	20

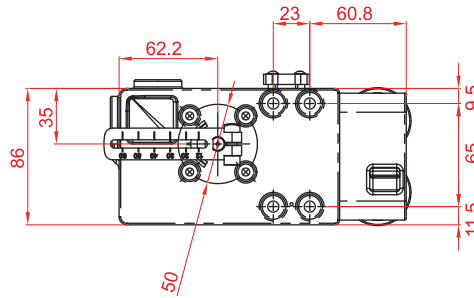

### - SS5R (Rotary Type)

Electrical connections  
2 - PF(NPT)1/2

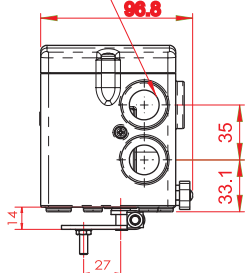

Electrical connections  
PF(NPT)1/2

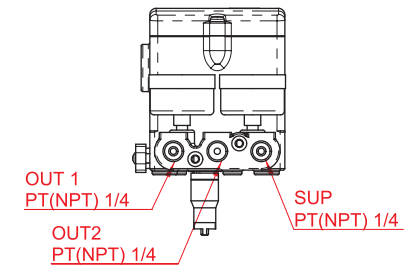
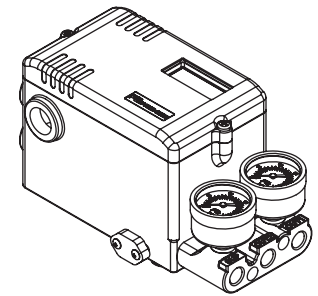
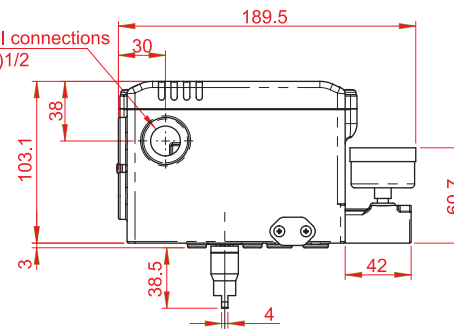

< Fork Lever Type >

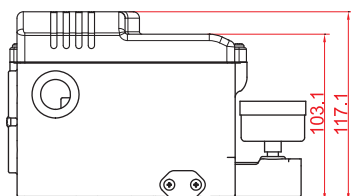

< SS5 with 2 x SPDT Micro S/W >

