

B Series Pneumatically-Operated

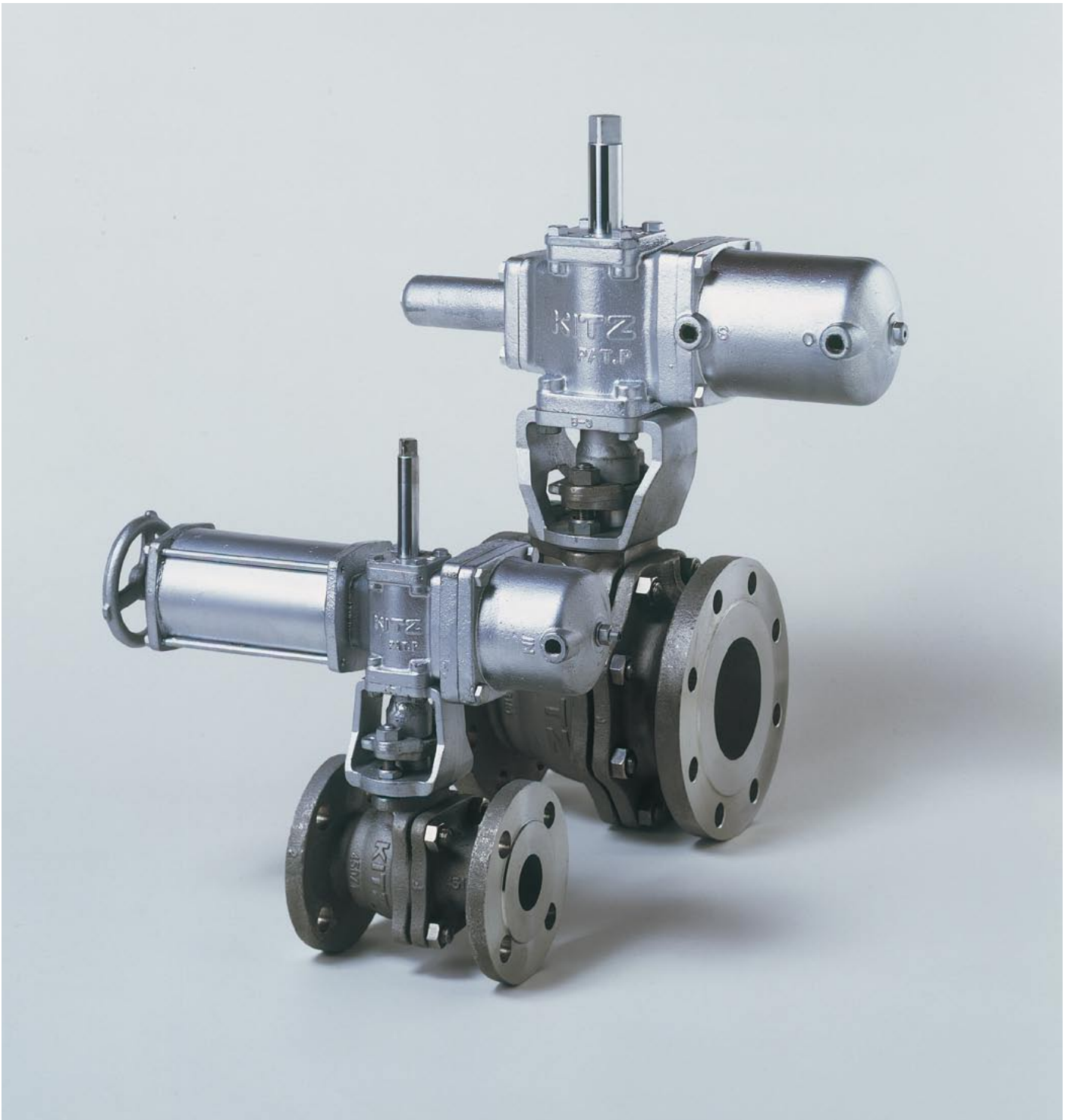

Contents

- Features of KITZ B Series Pneumatic Actuators 1
- Specifications and Dimensions..... 3
- Actuator Selection for KITZ Ball and Butterfly Valves 5
- Cylinder Volume and Air Supply Requirements..... 6
- Air Piping for Actuators..... 8
- KITZ Optional Actuator Accessories 9
- Construction Details of Type B Actuators..... 10
- Construction Details of Type BS Actuators..... 11
- Construction Details of Type BSW Actuators..... 12
- Valve and Actuator Handling Instructions..... 13

The products introduced in this catalog are all covered by the ISO 9001 Certification awarded KITZ Corporation in 1989, the earliest in the valve industry.

Foreword

Pneumatic actuators are generally recommended because they simplify piping arrangements and minimize environmental pollution problems. These are advantageous features when compared with hydraulically operated actuators. Also, unlike electric actuators, care required for inflammable or explosive servicing environments is much less when pneumatic actuators are installed.

Application of pneumatic actuators has grown dramatically in recent days for their cost and energy saving advantages. KITZ proudly introduces B Series pneumatic actuators which are readily mountable on all KITZ ball and butterfly valves. Ball or butterfly valves constructed similarly to KITZ valves may also be satisfactorily operated with KITZ pneumatic actuators.



KITZ Butterfly Valve with Type B Actuator



KITZ Ball Valve with Type BS Actuator



KITZ Ball Valve with fully equipped Type B Actuator

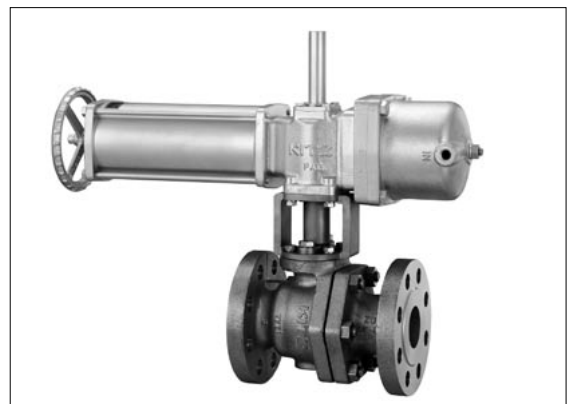

KITZ Ball Valve with Type BSW Actuator

Features of KITZ B Series Pneumatic Actuators

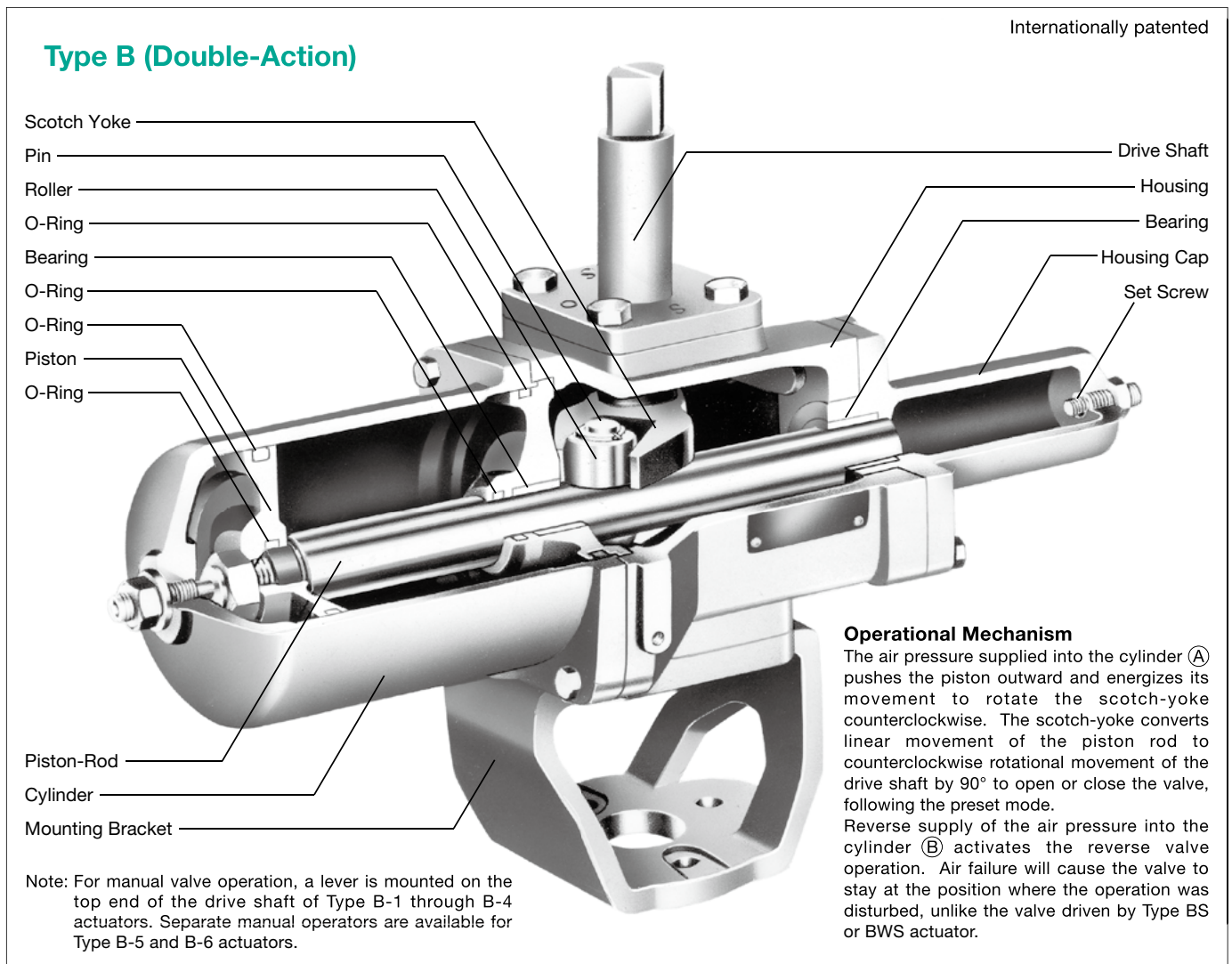

Smooth operation with minimum friction

Extensive use of fluorocarbon resin to coat inside parts of the actuator reduces friction to a minimum for smooth operation. This includes the inside of the cylinder, resulting in smooth sliding of the piston and O-rings, as well as the surfaces of driving shaft, piston rod, and all bearings. As a result, the actuator features long-term stable operation.

Simple, trouble-free construction

The number of parts has been minimized to reduce mechanical problems and simplify periodic check, maintenance, disassembly, or reassembly.

Separated turning mechanism and cylinder

Unlike conventional designs, in which the cylinder drive transmission mechanism is incorporated in the cylinder itself, the transmission mechanism of KITZ B Series actuators is designed with a scotch yoke installed separately from the cylinder.

This construction prevents air leakage even when the shaft clearance has increased during service.

Drive characteristics suited to quarter-turn valves

Unlike conventional cylinder actuators deploying linear drive characteristics, use of a scotch yoke mechanism provides a U-shape curve which maximizes the force obtained at the start and end areas of each stroke. This performance curve is similar to the torque characteristics of ball and butterfly valves in general, making KITZ B Series actuators suitable for such quarter-turn valves.

Installation of accessories

The actuator housing is provided with an arrangement for mounting limit switches and valve positioners, etc. on its top, and solenoid valves, air filters, and regulators on its side.

Internationally patented

Type BS (Spring-Return) Type BSW (Spring-Return with Manual Operation Device)

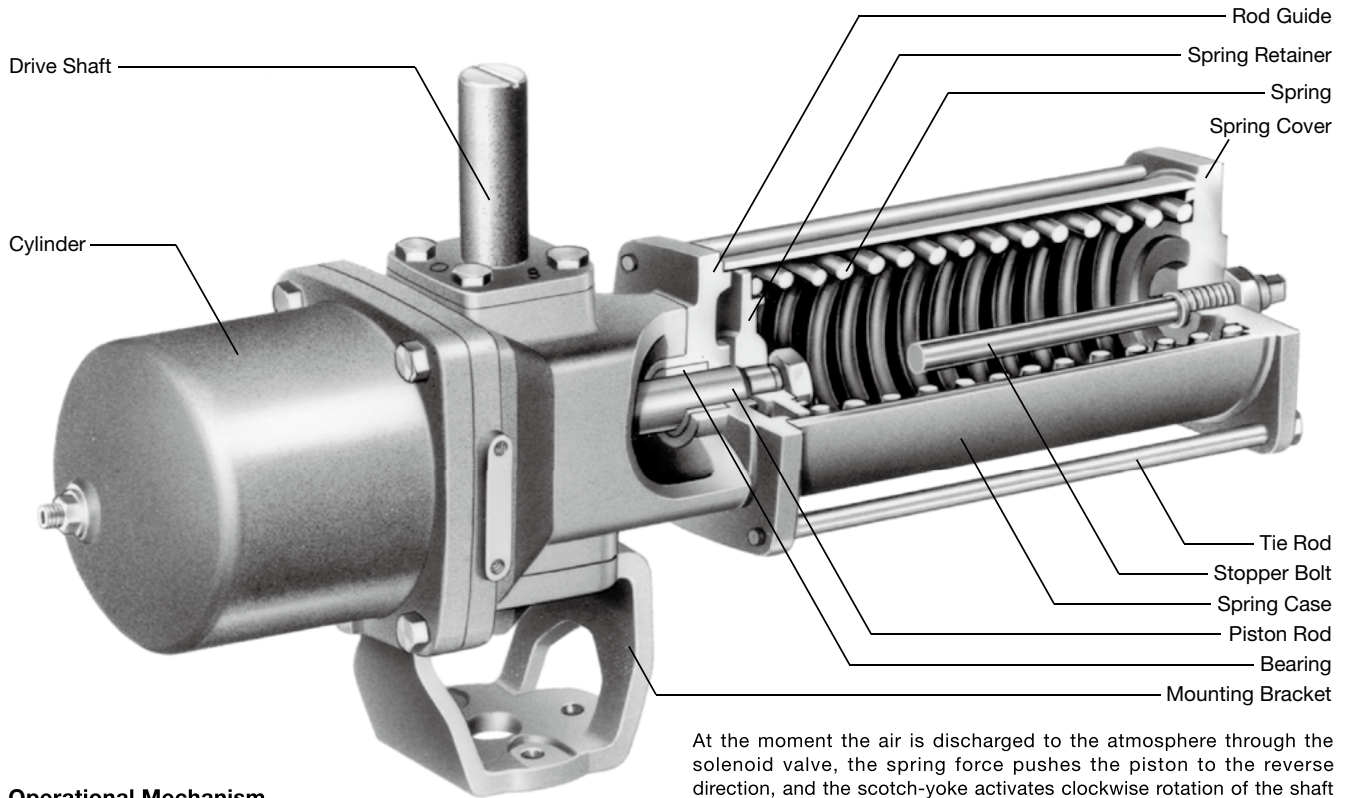

Operational Mechanism

The air pressure supplied into the cylinder pushes the piston outward and energizes its movement to rotate the scotch-yoke counterclockwise, compressing the spring. The scotch-yoke converts linear movement of the piston rod to counterclockwise rotational movement of the drive shaft by 90°, to open or close the valve, following the preset mode.

At the moment the air is discharged to the atmosphere through the solenoid valve, the spring force pushes the piston to the reverse direction, and the scotch-yoke activates clockwise rotation of the shaft to reversely operate the valve. Air failure will cause the valve to return to the original open or closed position automatically, following the preset mode, unlike the valve driven by Type B actuator.

The BSW actuator is driven with the same mechanism as Type BS, but provided with a handwheel for manual operation. Please bear it in mind that the handwheel must be **factory mounted**.

Type B Actuator Output Torque

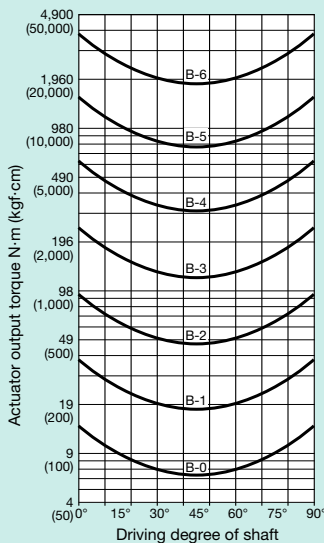

Type BS/BSW Actuator Output Torque

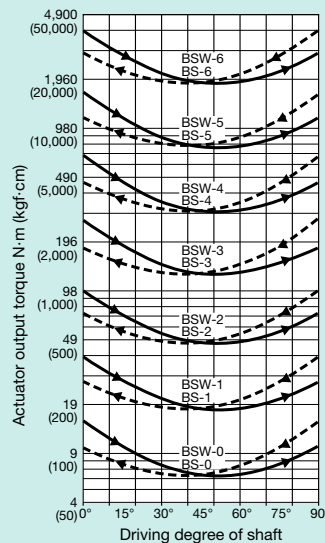

— Output torque when air pressure is supplied.
--- Output torque caused by spring force when air pressure is exhausted.

Operating pressure:
0.39MPa (4kgf/cm² or 60psi)

Specifications and Dimensions

Operating media	: Compressed instrumentation air
Standard operating pressure	: 0.39MPa (4kgf/cm ² or 60 psi): factory preset pressure
Pressure supply range	: 0.39MPa (4kgf/cm ² or 60 psi) to 0.69MPa (7kgf/cm ² or 100 psi)
Output torque	: Refer to Page 2
Standard durability	: 100,000 cycles under moderate service conditions
Housing test pressure	: 0.97MPa (9.9 kgf/cm ² or 140 psi)
Drive shaft rotation	: 100° (when the stopper is fully relaxed)
Rotation adjustment range	: 5° at each end
Service temperature range	: Standard: -20°C to +60°C (-4°F to +140°F) Option: -40°C to +60°C (-40°F to +140°F)

Type B (Double-Action)

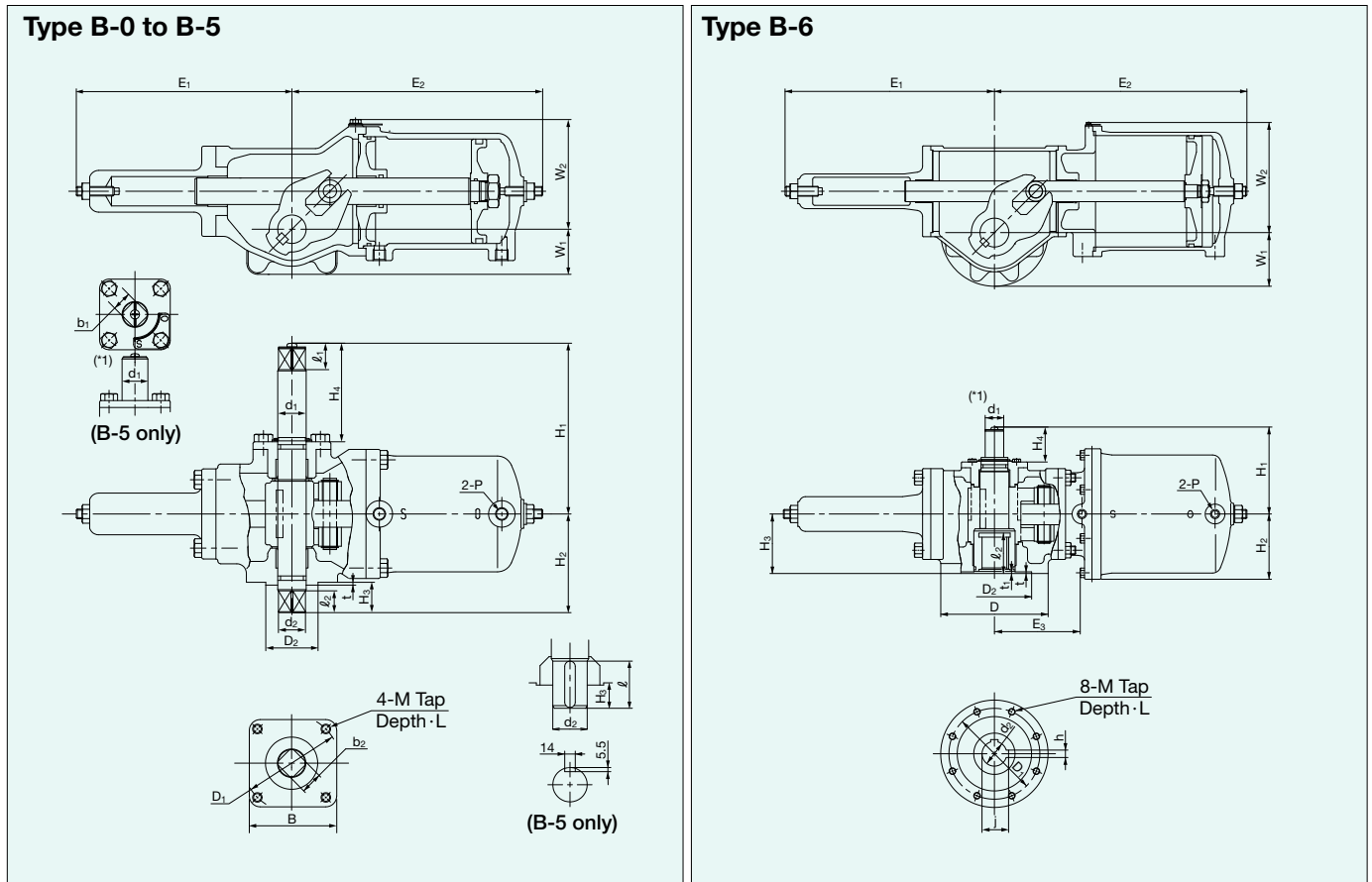

*1. The operating lever cannot be mounted on the drive shaft of Type B-5 and B-6 actuators.

Type B Actuator Dimensions

Type	E ₁	E ₂	E ₃	W ₁	W ₂	H ₁	H ₂	H ₃	H ₄	D	D ₁	D ₂	d ₁	d ₂	b ₁	b ₂	B	l ₁	l ₂	t	t ₁	P	L	M	h	J
B-0	92	111	—	25	54	75	53	18	40	—	50	35	12	15	10	12	50	15	12	2	—	Rc ¹ / ₈	9	M6	—	—
B-1	128	154	—	25	81	140	60	18	94	—	50	35	16	15	12	12	50	12	12	2	—	Rc ¹ / ₄	9	M6	—	—
B-2	177	205	—	35	89	153	77	23	99	—	70	55	22	21	17	17	70	17	17	2	—	Rc ¹ / ₄	12	M8	—	—
B-3	235	272	—	48	116	180	104	32	104	—	102	70	30	28.5	23	23	95	23	23	3	—	Rc ¹ / ₄	15	M10	—	—
B-4	289	333	—	57	149	230	138	43	127	—	125	85	45	41	32	32	114	32	32	3	—	Rc ¹ / ₄	19	M12	—	—
B-5	372	428	—	81	203	225	167	34	91	—	165	130	45	46	—	—	162	63	63	3	—	Rc ¹ / ₂	32	M20	—	—
B-6	532	636	212	130	267	208	158	144	82	260	220	180	45	60	—	—	—	—	99	4	5	Rc ¹ / ₂	26	M16	18	64.4

Type BS (Spring-Return)

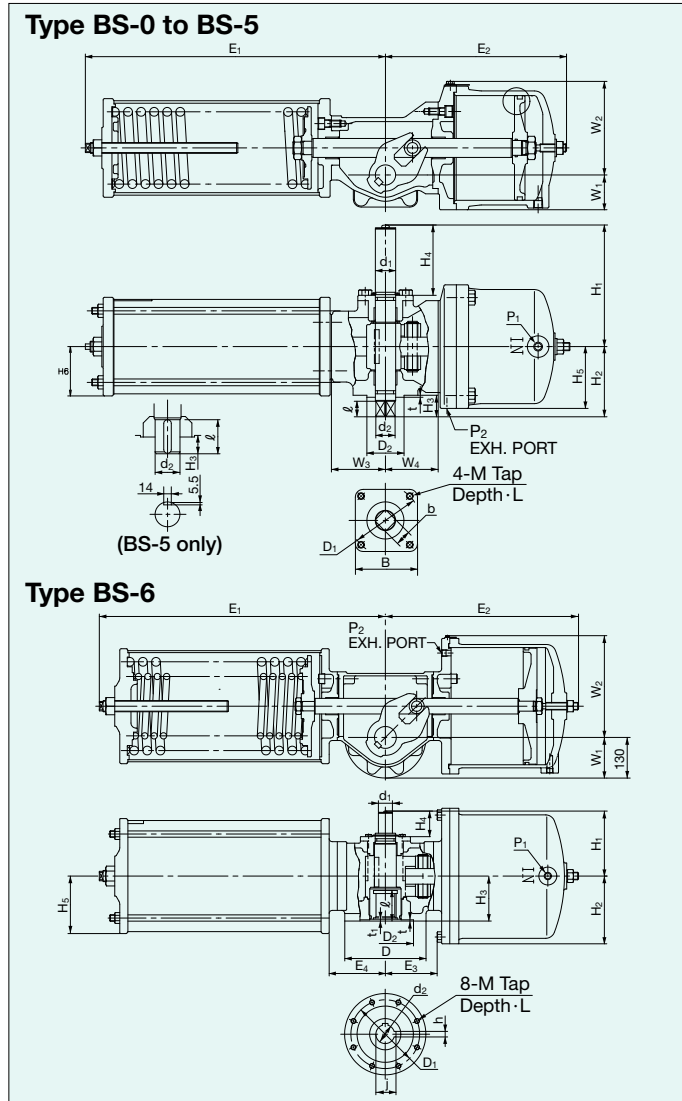

Type BSW (Spring-Return with Manual Operation Device)

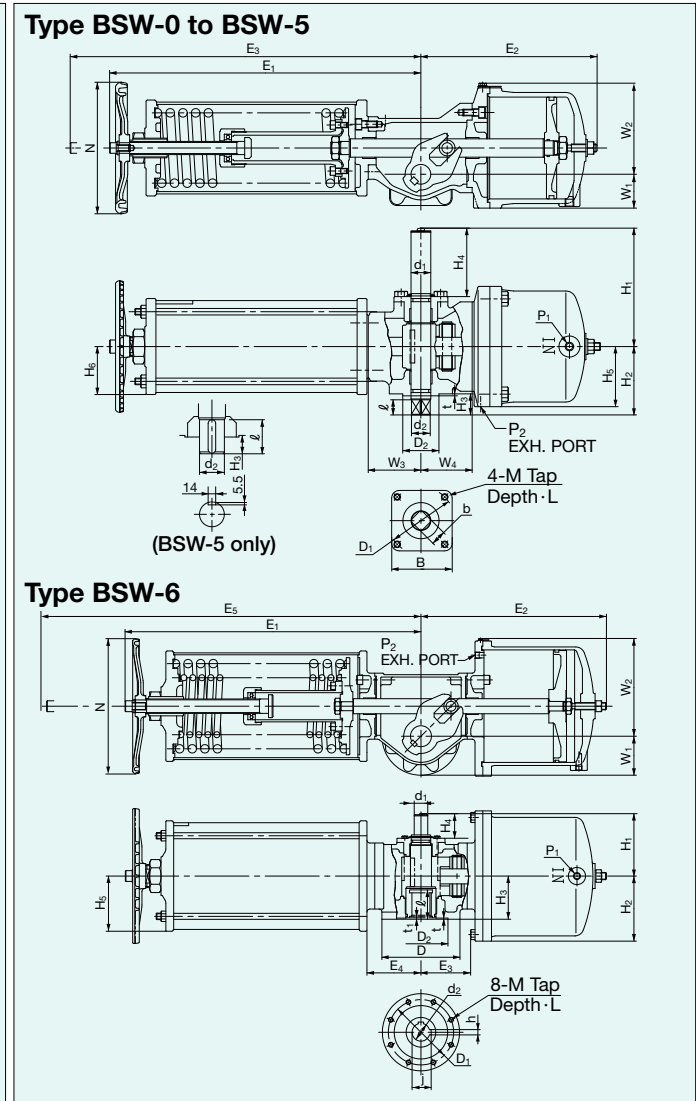

Type BS Actuator Dimensions

Type	E ₁	E ₂	E ₃	E ₄	W ₁	W ₂	W ₃	W ₄	H ₁	H ₂	H ₃	H ₄	H ₅	H ₆	D	D ₁	D ₂	d ₁	d ₂	b	B	l	t	t ₁	M	L	h	j	P ₁	P ₂
BS-0	163	127	—	—	40	62	—	38	75	53	18	40	41	—	50	35	12	15	12	50	12	2	—	M6	9	—	—	Rc ¹ / ₈	Rc ¹ / ₈	
BS-1	239	166	—	—	30	83	47	38	140	60	18	94	52	46	50	35	16	15	12	50	12	2	—	M6	9	—	—	Rc ¹ / ₄	Rc ¹ / ₈	
BS-2	335	215	—	—	38	106	62	56	153	77	23	99	68	54	70	55	22	21	17	70	17	2	—	M8	12	—	—	Rc ¹ / ₄	Rc ¹ / ₈	
BS-3	451	286	—	—	52	140	80	78	180	104	32	104	92	73	102	70	30	28.5	23	95	23	3	—	M10	15	—	—	Rc ¹ / ₄	Rc ¹ / ₄	
BS-4	575	361	—	—	81	188	100	91	230	138	43	127	130	99	125	85	45	41	32	114	32	3	—	M12	19	—	—	Rc ¹ / ₂	Rc ¹ / ₄	
BS-5	745	461	—	—	117	256	128	114	225	167	34	91	182	139	165	130	45	46	—	162	63	3	—	M20	32	—	—	Rc ¹ / ₂	Rc ¹ / ₄	
BS-6	931	638	169	180	130	326	—	—	208	217	144	82	184	—	260	220	180	45	60	—	—	99	4	5	M16	26	18	64.4	Rc ¹ / ₂	Rc ¹ / ₂

Type BSW Actuator Dimensions

Type	E ₁	E ₂	E ₃	E ₄	E ₅	W ₁	W ₂	W ₃	W ₄	H ₁	H ₂	H ₃	H ₄	H ₅	H ₆	D	D ₁	D ₂	d ₁	d ₂	b	B	l	t	t ₁	M	L	h	j	N	P ₁	P ₂
BSW-0	185	127	218	—	—	40	62	—	38	75	53	18	40	41	—	50	35	12	15	12	50	12	2	—	M6	9	—	—	90	Rc ¹ / ₈	Rc ¹ / ₈	
BSW-1	259	166	315	—	—	30	83	47	38	140	60	18	94	52	46	50	35	16	15	12	50	12	2	—	M6	9	—	—	100	Rc ¹ / ₄	Rc ¹ / ₈	
BSW-2	362	215	438	—	—	38	106	62	56	153	77	23	99	68	54	70	55	22	21	17	70	17	2	—	M8	12	—	—	140	Rc ¹ / ₄	Rc ¹ / ₈	
BSW-3	482	286	582	—	—	52	140	80	78	180	104	32	104	92	73	102	70	30	28.5	23	95	23	3	—	M10	15	—	—	200	Rc ¹ / ₄	Rc ¹ / ₄	
BSW-4	609	361	734	—	—	81	188	100	91	230	138	43	127	130	99	125	85	45	41	32	114	32	3	—	M12	19	—	—	250	Rc ¹ / ₂	Rc ¹ / ₄	
BSW-5	795	461	956	—	—	117	256	128	114	225	167	34	91	182	139	165	130	45	46	—	162	63	3	—	M20	32	—	—	300	Rc ¹ / ₂	Rc ¹ / ₄	
BSW-6	1006	638	169	180	1250	130	326	—	—	208	217	144	82	184	—	260	220	180	45	60	—	—	99	4	5	M16	26	18	64.4	450	Rc ¹ / ₂	Rc ¹ / ₂

Actuator Selection for KITZ Ball and Butterfly Valves

The operating torque of a valve varies according to fluid conditions such as pressure, temperature, velocity, viscosity and density. The following actuator sizes are recommended for typical light or heavy load service with the fluid conditions specified below. Selection of Type B listed here can be also applied to selection of Type BS and Type BSW.

IMPORTANT

Selection of actuators is very critical when:

- (1) Fluid pressure is higher than that listed below.
- (2) Fluid velocity is extremely high.
- (3) Operational interval exceeds three months.
- (4) Operating pressure is lower than 0.39MPa (4kgf/cm² or 60 psi)

For TDZ Series, Full Bore Dsgn

Size	in	1/2 ^B	3/4 ^B	1 ^B	1 1/2 ^B	2 ^B	2 1/2 ^B	3 ^B	4 ^B	5 ^B	6 ^B	8 ^B	10 ^B
	mm	15 ^A	20 ^A	25 ^A	40 ^A	50 ^A	65 ^A	80 ^A	100 ^A	125 ^A	150 ^A	200 ^A	250 ^A
Fluede Service Condition		A B C	A B C	A B C	A B C	A B C	A B C	A B C	A B C	A B C	A B C	A B C	A B C
Flued Pressure	MPa												
	0.5												
	1.0	B-0	B-0 B-1	B-1	B-2			B-3		B-4		B-5	B-6
	1.5												
	2.0						B-3				B-5		
2.5													

*Consult KITZ distributors for availability of appropriate actuators.

For TB Series

Size	Full Bore Type in(mm)	1/2 ^B (15 ^A)	3/4 (20)	1 (25)	1 1/4 (32)	1 1/2 (40)	2 (50)	2 1/2 (65)	3 (80)	4 (100)	5 (125)	6 (150)	8 (200)	10 (250)
	Reduce bore Type in(mm)	3/4 ^B (20 ^A)	1 (25)	1 1/4 (32)	1 1/2 (40)	2 (50)	—	3 (80)	4 (100)	5 (125)	6 (150)	8 (200)	10 (250)	12 (300)
Fluede Service Condition		A B C	A B C	A B C	A B C	A B C	A B C	A B C	A B C	A B C	A B C	A B C	A B C	A B C
Flued Pressure	MPa													
	0.5	B-0	B-0	B-0	B-1							B-4		
	1.0						B-2	B-2	B-3					B-6
	1.5					B-2					B-4		B-5	
	2.0						B-3		B-4	B-4	B-5		B-6	
2.5														

*Consult KITZ distributors for availability of appropriate actuators.

Fluid Condition

Fluids	Service Condition	Light Load Service	Heavy Load Service
Water		up to 0.98MPa (10kgf/cm ² or 150psi.): A	0.98~2.45MPa (10~25kgf/cm ² or 150~350psi.): B
Air, steam and gases		up to 0.69MPa (7kgf/cm ² or 150psi.): A	0.69~1.77MPa (7~18kgf/cm ² or 100~255psi.): B
Highly viscous fluid			up to 0.98MPa (10kgf/cm ² or 150psi.) : B
Kerosene, naphtha, alcohol, and other solvents			up to 0.98MPa (10kgf/cm ² or 150psi.) : B
Oil-free service			up to 0.98MPa (10kgf/cm ² or 150psi.) : B
Slurry and other liquids containing foreign objects			up to 0.98MPa (10kgf/cm ² or 150psi.) : C
Service temperature: Fluids temperature		See valve seat rating of "Ball Valves Catalog" (E-205)	

Cylinder Volume and Air Supply Requirements

On installation of piping for actuators, air requirements of actuators should be carefully studied to ensure that a sufficient pressure is provided. Actuators should be activated by clean

air which is made free from moisture by air driers. For frequent operation, occasional lubrication is recommended for higher efficiency and longer service life.

Cylinder volume for Type B actuators

Cylinder Type	V_1	V_2
B-0	0.05	0.07
B-1	0.17	0.17
B-2	0.43	0.43
B-3	1.04	1.09
B-4	2.69	2.75
B-5	6.53	6.80
B-6	15.90	14.20

(liters)

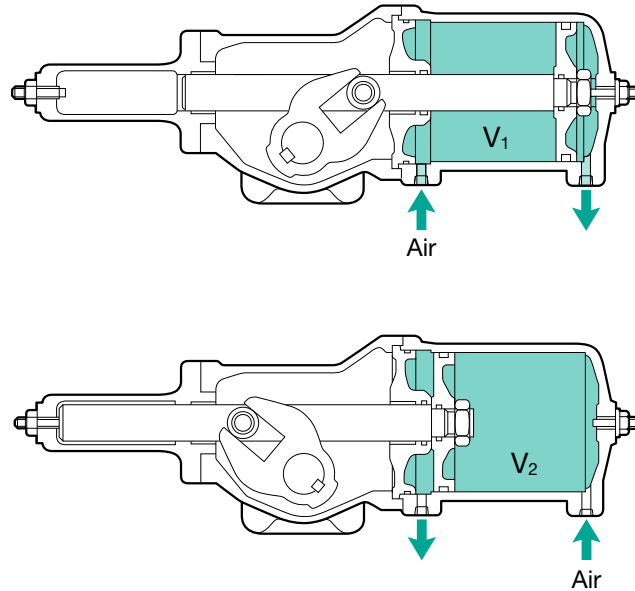

Cylinder volume for Type BS/BSW actuators

Cylinder Type	V
BS-0/BSW-0	0.17
BS-1/BSW-1	0.33
BS-2/BSW-2	0.82
BS-3/BSW-3	2.23
BS-4/BSW-4	5.39
BS-5/BSW-5	13.70
BS-6/BSW-6	30.20

(liters)

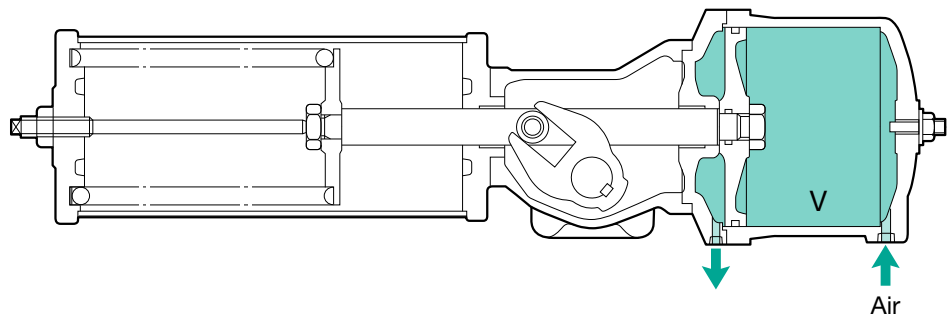

Air Supply Requirement (Flow Rate)

Actuators should be supplied with the air sufficient to operate the valve through a full stroke from the open to closed position or vice versa in “t” seconds, as converted into flow rate per minute. The required air volume “Q” is calculated as follows.

$$Q = V \left(\frac{P+0.1013}{0.1013} \right) \times \frac{60}{t} \text{ (Nℓ/min.)}$$

Q = Air supply requirement per minute (Nℓ/min.)

V = Cylinder volume (liters)

V₁ or V₂, whichever larger, for Type B actuators

P = Supply pressure (MPaG)

t = Time required per stroke (seconds)

All accessories to be mounted on the actuator such as solenoid valves, air filters, regulators, and air supply pipes, should have sufficient capacity to accommodate air flow rate (Q) calculated here.

Air Consumption

Air consumption means the volume of air discharged into the atmosphere from an actuator operating “n” cycles (two strokes) per hour as converted into volumes per minute. The value is calculated as follows.

Type B actuator:

$$Q = (V_1 + V_2) \left(\frac{P+0.1013}{0.1013} \right) n \times \frac{1}{60} \text{ (Nℓ/min.)}$$

Type BS or BSW actuator:

$$Q = V \left(\frac{P+0.1013}{0.1013} \right) n \times \frac{1}{60} \text{ (Nℓ/min.)}$$

For selecting compressors and air reservoirs for these actuators, determine the capacities based on the air consumption values obtained from the above calculations, adding an extra 30% as allowance for possible loss of air caused by solenoid valves, accessories, piping, etc.

⚠ CAUTION

1. For manual operation, ensure in advance to (a) shut off the supply of air and (b) discharge of the air left in the housing to the atmosphere.
For double-action actuators, the pressure equalizing valve should be opened in advance.
2. After manual operation, the lever handle should be removed. Operating actuators with handles attached is extremely dangerous.
3. Long bolts securing the spring case should not be loosened or unthreaded, unless required for maintenance, particularly in case of manual operation of spring-return actuators. A compressed spring may suddenly break out, causing an extreme danger.
4. KITZ Operation Manual is available for safe and efficient operation of KITZ B Series actuators, on request.

Manual Operation

For double-action type actuators, manual lever handles for Type B-1 through B-4, and manual operation devices for Type B-5 and B-6 are readily available.

For spring-return type actuators, specify Type BSW on your order for provision of manual operation.

Air Piping for Actuators

When installing pipes (either copper pipes or covered copper pipes) for air supply to actuators:

1. Select pipes of suitable diameter and wall thickness, according to the table given below.

2. Seal all pipe joints securely to avoid leakage since accessories are mounted along the pipes between air supply source and actuator. Use PTFE tapes for sealing, making sure that loose tape ends do not extend into the pipe: they may block ports and air supply may be adversely effected.

Diameter of piping threads (Rc)

Size	-0	-1	-2	-3	-4	-5	-6
Type B	1/8	1/4	1/4	1/4	1/4	1/2	1/2
Type BS / BSW	1/8	1/4	1/4	1/4	1/2	1/2	1/2

Type B Actuators (Double-Action)

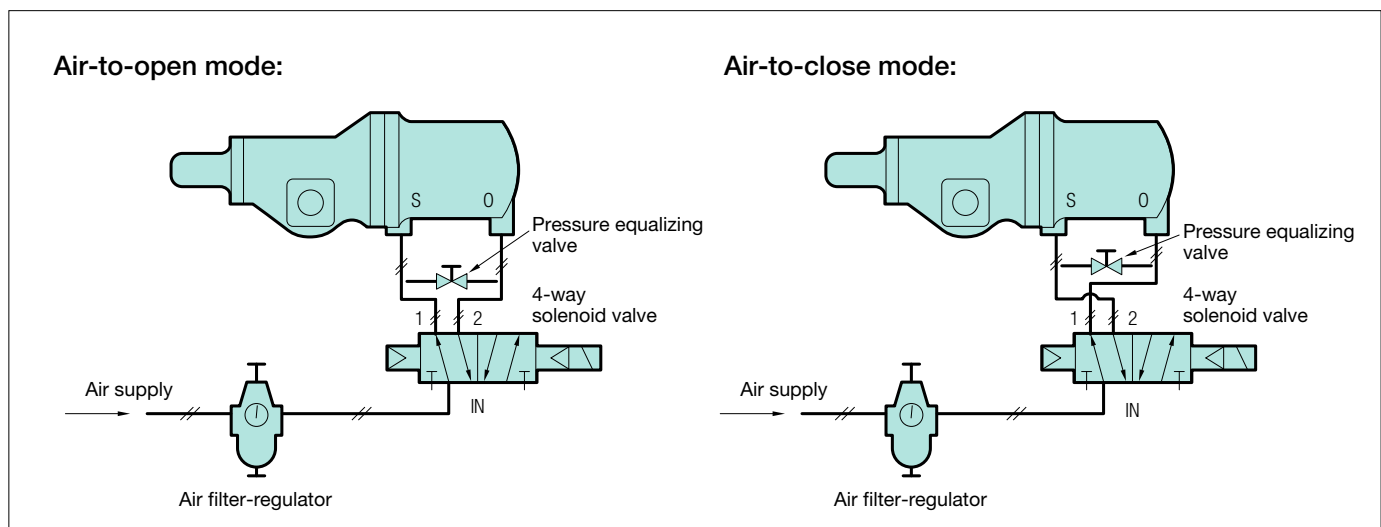

Type BS/BSW Actuators (Spring-return)

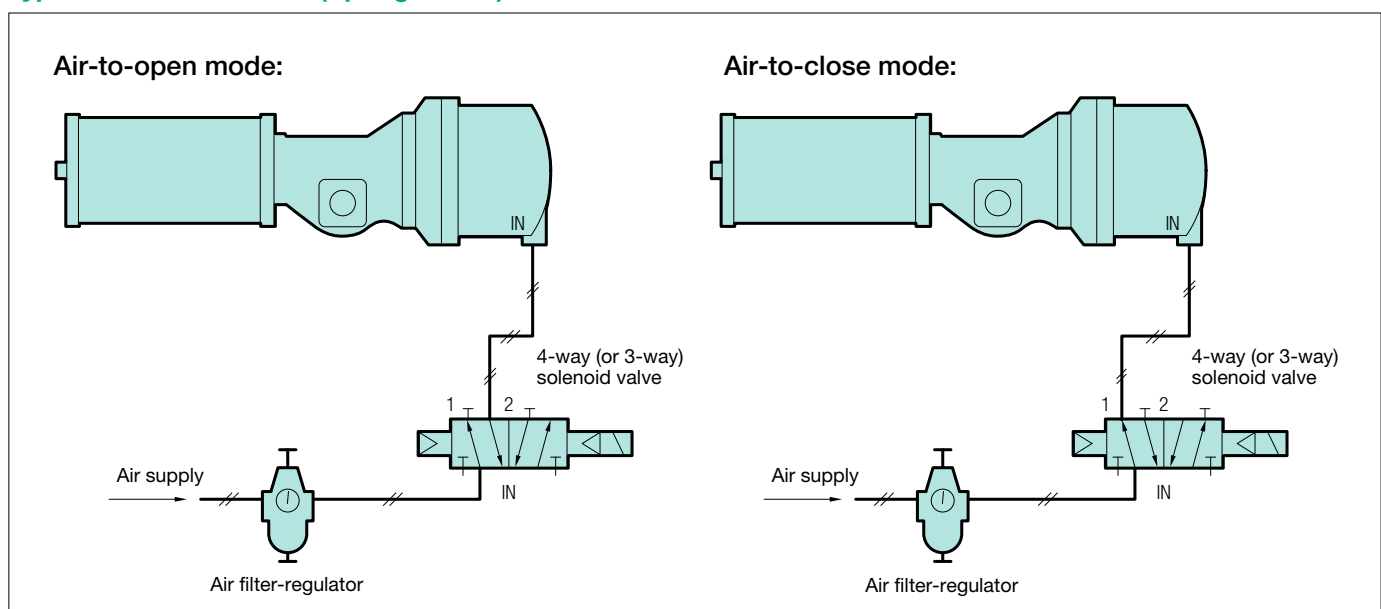

Circuit diagrams of solenoid valves indicate that they are NOT energized.

KITZ Optional Actuator Accessories

The following optional accessories are recommended for KITZ B Series actuators.
For supply of other accessories, contact your local KITZ distributors.

Product code	Purpose	Specifications
Limit Switch LS Weather-proof LS-F Explosion-proof	For initiating electric signals to check open or close position of the valve: A separate limit switch is recommended for each of open and close indication.	LS AC: 10A/125V 10A/250V 10A/480V DC: 0.8A/115V 0.4A/230V LS-F AC: 5A/125V 5A/250V DC: 0.8A/125V 0.4A/250V Contact circuit: 2-Circuit double break
Solenoid Valve SOV Weather-proof SOV-F Explosion-proof	Flow switching over air flow by electric signal; 4-way solenoid valves for double-action actuators, 4-way solenoid valves for spring-return actuators, with one OUT port plugged, or 3-way solenoid valves used.	Connected pipe: Rc1/4 Working pressure: 0~0.97MPa (0~9.9kgf/cm ² or 0~140psi.) Orifice diam: 6mm Electric current: 100V/50Hz 100V/60Hz 110V/60Hz 200V/50Hz 200V/60Hz 220V/60Hz Supply source connection Weather-proof: DIN terminals or terminal boxes Explosion-proof: Electric wire pipe threading
Air Filter-Regulator F + R (Complete with pressure gauge)	For removing moisture, water and other foreign objects from operating air and for regulating air pressure at a desire level.	Connected pipe: Rc1/4, Rc1/2 Working pressure: Max. inlet pressure; 0.97MPa (9.9kgf/cm ² or 140psi.) Max. outlet pressure; 0.04~0.83MPa (0.5~8.5kgf/cm ² or 8~120psi.)
Speed Controller SP	For reducing actuator operating speeds.	Connected pipe: Rc1/8, Rc1/4, Rc1/2 Operation pressure: 0.97MPa (9.9kgf/cm ² or 140psi.) max.
Quick Exhaust Valve QE	For increasing actuator operation speed. This device can increase operation speed only when the actuator is operated by the spring. Positioners cannot be used together with a quick exhaust valves.	Connected pipe: Rc1/4, Rc1/2 Working pressure: 0.97MPa (9.9kgf/cm ² or 140psi.) max.
Valve Positioner P (Complete with pressure gauge)	For controlling the flow rate. A positioners can be mounted on either double-action or spring-return actuators. Operation modes, air-to-open or air-to-close, can be changed simply by reversing cam direction.	Connected pipe: Rc1/4 (pressure gauge: Rc1/8) Supply pressure: 0.29~0.69MPa (3~7kgf/cm ² or 43~100psi.) Signal pressure: 0.02~0.1MPa (0.2~1.0kgf/cm ² or 3~15psi.) or specified Linearity: ±2% max. Hysteresis: 1% max. Air consumption: 20Nℓ/min. max. (at supply pressure 0.49MPa (5kgf/cm ² or 70psi.))
Silencer K	For reducing the air exhaust noise of solenoid valves. The device is installed at the exhaust port of a solenoid valve.	Connected pipe: Rc1/8, Rc1/4, Rc1/2 Working pressure: 0.9MPa (9.2kgf/cm ² or 130psi.) max.
Air Filter F	For removing moisture, water and other foreign objects from operating air.	Connected pipe: Rc1/4, Rc1/2 Working pressure: 0.97MPa (9.9kgf/cm ² or 140psi.) max.
Lubricator L	Basically, KITZ B Series actuators and their solenoid valves can be operated lubrication-free. However, when actuators are subject to high frequency of operation for long period of time, lubrication is recommended.	Connected pipe: Rc1/4, Rc1/2 Working pressure: 0.97MPa (9.9kgf/cm ² or 140psi.) max. Recommended oil: Turbine oil #90~#140
Pressure Equalizing Valve C	For equalizing the internal air pressure to the atmospheric level for manual operation of actuators.	Connected pipe: Rc1/4 Working pressure: 1.37MPa (14kgf/cm ² or 200psi.) max.

Above specifications are KITZ standards. Different specifications are optionally available.

Construction Details of Type B Actuators

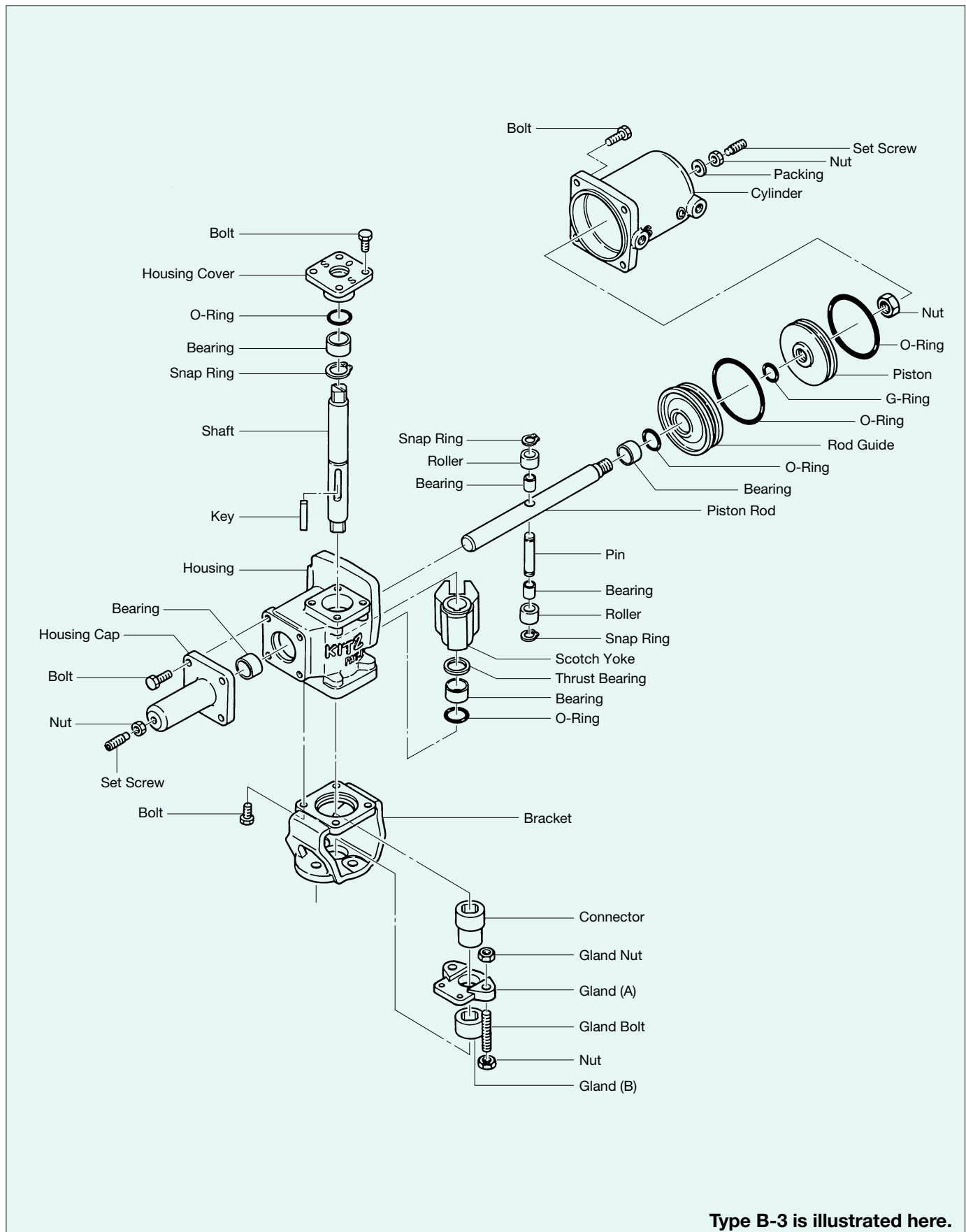

Type B-3 is illustrated here.

Construction Details of Type BS Actuators

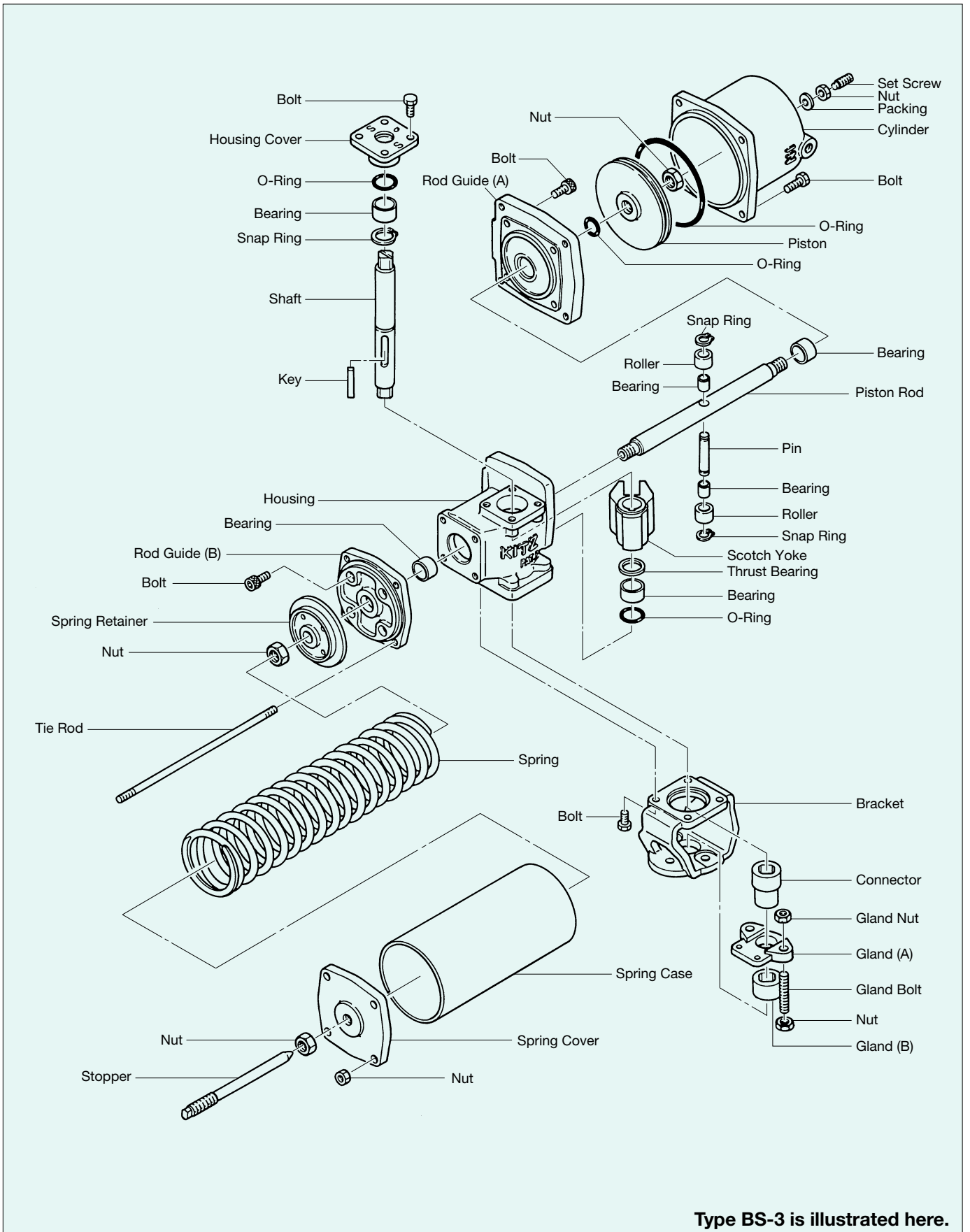

Construction Details of Type BSW Actuators

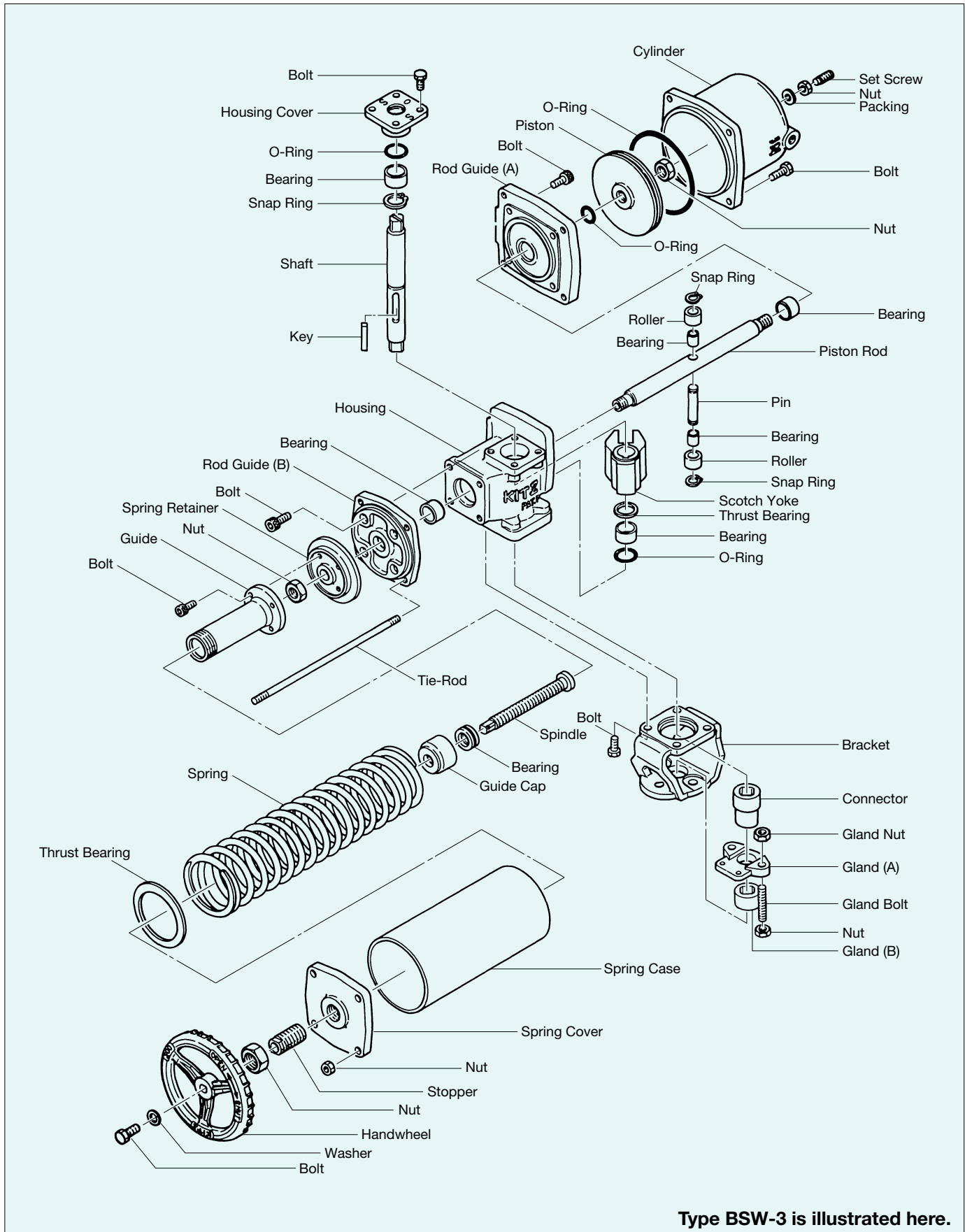

Type BSW-3 is illustrated here.

Valve and Actuator Handling Instructions

1. Before mounting valves on pipelines, remove welding chips, scales and other foreign objects from the ports; flush the insides thoroughly.
2. Both pneumatically operated ball and butterfly valves can be mounted horizontally or vertically. Fluid can be discharged from either port. However, air filters and lubricators attached to actuators should be correctly positioned in consideration of the weight of actuators which may cause an extra stress on the pipeline.
3. For convenience of maintenance service, provide an adequate room around valves, such as 300 mm above, 500 mm below, and 300 mm wide from the sides.
4. Ambient temperatures allowable for actuators ranges between -20°C and $+60^{\circ}\text{C}$. Valves should be adequately protected if the ambient temperature exceeds this range.
5. If a pipeline vibrates, take appropriate prevention measures.
6. In corrosive atmospheres such as SO_2 or Cl_2 , corrosive gas should not be intruded into the air supply.
7. Use air compressors and air reservoirs with a capacity of 130% of the piping capacity and air consumption.
The maximum supply air pressure for KITZ B Series actuators is 0.69MPa (7kgf/cm² or 100psi.).
8. During the initial operation, or after suspension of operation exceeding 3 month, operating torque may exceed the specified level. In these cases, actuators should be manually operated several times before starting pneumatic activation.

CAUTION

Pressure-temperature ratings and other performance data published in this catalog have been developed from our design calculation, in-house testing, field reports provided by our customers and / or published official standards or specifications. They are good only to cover typical applications as a general guideline to users of KITZ products introduced in this catalog.

For any specific application, users are kindly requested to contact KITZ Corporation for technical advice, or to carry out their own study and evaluation for proving suitability of these products to such an application. Failure to follow this request could result in property damage and / or personal injury, for which we shall not be liable.

While this catalog has been compiled with the utmost care, we assume no responsibility for errors, impropriety or inadequacy. Any information provided in this catalog is subject to from-time-to-time change without notice for error rectification, product discontinuation, design modification, new product introduction or any other cause that KITZ Corporation considers necessary. This edition cancels all previous issues.

Read instruction manual carefully before use.

NOTICE

If any products designated as strategic material in the Foreign Exchange and Foreign Trade Law, Cabinet Order Concerning Control of Export Trade, Cabinet order Concerning Control of Foreign Exchange and other related laws and ordinances ("Foreign Exchange Laws") are exported to any foreign country or countries, an export license issued by the Japanese Government will be required under the Foreign Exchange Laws.

Further, there may be cases where an export license issued by the government of the United States or other country will be required under the applicable export-related laws and ordinances in such relevant countries.

The contract shall become effective subject to that a relevant export license is obtained from the Japanese Government.

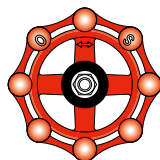

*A chrysanthemum-handle is a symbol of KITZ,
the brand of valve reliability*

ISO 9001 certified since 1989

KITZ
KITZ CORPORATION

1-10-1, Nakase, Mihama-ku, Chiba 261-8577, Japan
International Sales Dept.

Phone : 81-43-299-1730, 1732 and 1733

Fax : 81-43-299-0121

— Distributed by —