

CONTENTS

Introduction.	5
Safety Information	5
Unpacking & Inspection	5
Installation.	5
Straight Pipe Run Requirements for SSL, SSM, LPL, VISSL, VISSM, VILPL.	5
Straight Pipe Run Requirements for CV, VBR.	7
Selecting a Mounting Location	7
Line Installation.	9
Differential Pressure Connections	10
Specifications.	11

INTRODUCTION

Preso Venturi flow meters are differential pressure flow devices providing highly accurate and repeatable measurements of liquids, gases, and steam. The Venturi flow meter restricts the flow at its throat, increasing the velocity of the fluid, and measures the pressure difference of the unrestricted flow and restricted flow. The meter's throat can be designed to meet the flow measurement application optimizing the meter's accuracy and permanent pressure loss.

The Venturi flow meter's design provides longer lasting accuracy and lower permanent pressure loss than orifice type meters, reducing maintenance and operating costs. The Venturi flow meter can be built to meet the highest pressure and temperature specifications often limited in other flow meter technologies. All models can also be supplied with RTDs and transmitters to provide an economical mass flow measurement solution.

Safety Information

The installation of the Venturi flow meter must comply with all applicable federal, state, and local rules, regulations, and codes.

Failure to read and follow these instructions can lead to misapplication or misuse of the Venturi flow meter, resulting in personal injury and damage to equipment.

Unpacking & Inspection

Upon opening the shipping container, visually inspect the product and applicable accessories for any physical damage such as scratches, loose or broken parts, or any other sign of damage that may have occurred during shipment.

NOTE: If damage is found, request an inspection by the carrier's agent within 48 hours of delivery and file a claim with the carrier. A claim for equipment damage in transit is the sole responsibility of the purchaser.

INSTALLATION

Straight Pipe Run Requirements for SSL, SSM, LPL, VISSL, VISSM, VILPL

As with most flow elements, proper operation and performance is dependent on the required lengths of unrestricted upstream and downstream piping. The recommended minimum length of the upstream side of the Venturi flow element depends on the type of fitting at the start of the straight run and the pipe configuration. A fully developed symmetrical flow profile is achieved with the minimum upstream and downstream lengths as shown in *Figure 1*.

		MODEL	THROAT SIZE		BETA RATIO	
		SSL / VISSL – Classical SSM / VISSM – Nozzle	-1	0.35		
			-2	0.49		
INSTALLATION DISTURBANCE		LPL / VILPL – Low-Loss	-3	0.63		
			-4	0.75		
			-10	0.35		
			-20	0.49		
		Minimum Recommended Pipe Diameters				
			-1	-2	-3	-4
			-10	-20	-38	-65
Single elbow		A	4	4	4	5
		B	2	2	2	2
Two elbows in the same plane		A	8	8	9	10
		B	3	3	3	3
Two elbows in different planes		A	15	15	15	20
		B	4	4	4	4
Reducer		A	6	6	6	7
		B	2	2	2	2
Expander		A	8	8	8	10
		B	3	3	3	3
Tee connection with different diameters		A	8	8	8	10
		B	3	3	3	3
Globe / Gate valve fully opened		A	6	6	6	3
		B	3	3	3	3
Globe / Gate valve partially opened		A	12	12	14	18
		B	3	3	3	3

Figure 1: Venturi flow meter pipe diameter recommendations SSL, SSM, LPL, VISSL, VISSM and VILPL models

NOTES:

1. For upstream and downstream lengths equal to one half the values shown, add 2 percent to the accuracy value.
2. Install the flow conditioner in the straight length between the primary element and the upstream distance, or the fitting closest to the element. The straight lengths between fitting and conditioner should be at least 5D and the length between conditioner and Venturi meter should be at least 8D.
3. For other fittings and configurations, consult Badger Meter.
4. Reference: ISO-5167, "Flow Measurement Engineering Handbook", R.W. Miller.

Straight Pipe Run Requirements for CV, VBR

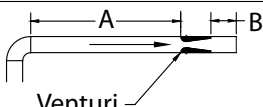
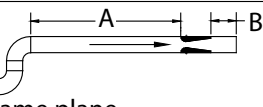
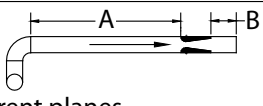
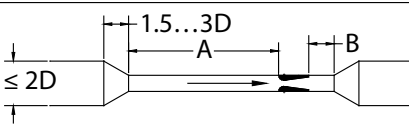
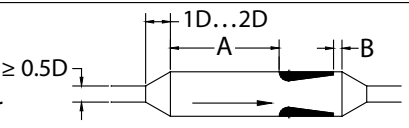
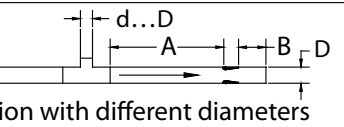
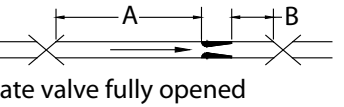
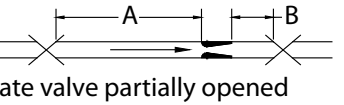
Preso CV and VBR Model Venturi elements can be installed in any position with minimal straight pipe run requirements. The recommended minimum lengths for these models are five pipe diameters upstream and two pipe diameters downstream.

Selecting a Mounting Location

The primary Venturi station can be installed in any position on vertical or horizontal lines. However, on horizontal liquid lines where the risk of gas/gas entrapment in the meter tubing is prevalent, install the element with the connections *below* the horizontal center line. For horizontal air or gas lines, install the element with the connection *above* the horizontal centerline. For steam lines, to protect the transmitter, install the element so that the connections are in the horizontal centerline on meters with the instrument taps in the same plane. See *Figure 5* for meters with instrument taps that are not in the same plane. Make sure that the flow arrow or the indicated inlet is correctly oriented. Other positions are acceptable provided the secondary element is properly vented and differences in tap line elevations are considered.

Vertical installations may introduce a slight hydrostatic head effect, which must be considered when zeroing a transmitter. Use a three-valve manifold, particularly for zeroing a transmitter.

Each flow element has an arrow indicating the required direction of flow. Failure to properly orient the Venturi element according to the direction of flow will cause improper results.

For Venturi elements supplied with lifting rings, make sure the connections are in the desired position for their application. The location of the supplied lugs may not be appropriate for all applications and may require other means of lifting.

⚠ WARNING

NEVER EXCEED THE MAXIMUM PRESSURE OR TEMPERATURE RECOMMENDED FOR THE MEASURED PROCESS. EXCEEDING PROPER PRESSURE OR TEMPERATURE RATINGS CAN LEAD TO PERSONAL INJURY OR EQUIPMENT DAMAGE. THE PROCESS PIPING FLANGES SHOULD BE IDENTICAL TO THOSE ON THE VENTURI METER. THE PROCESS TEMPERATURE AND PRESSURE SHOULD NEVER EXCEED THOSE FOR WHICH THE ELEMENT HAS BEEN DESIGNED.

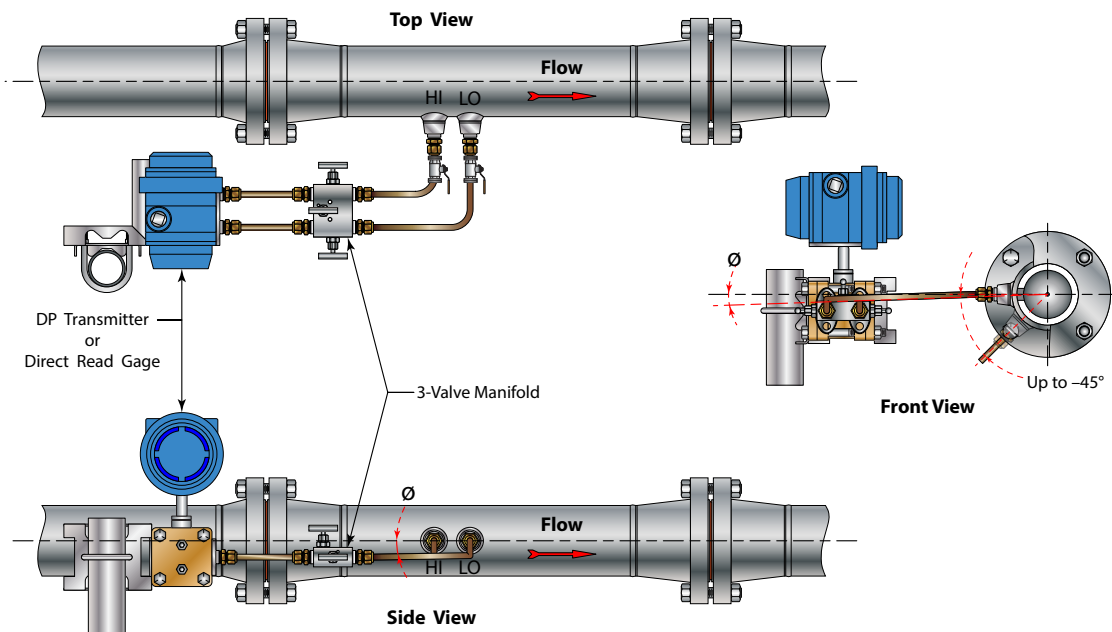

Notes:

1. $\varnothing = 1$ in/ft (80 mm/m) for water; 2...4 in/ft (160...320 mm/m) for more viscous fluids.
2. Minimize all lead line lengths.

Figure 2: Typical horizontal installation for liquid

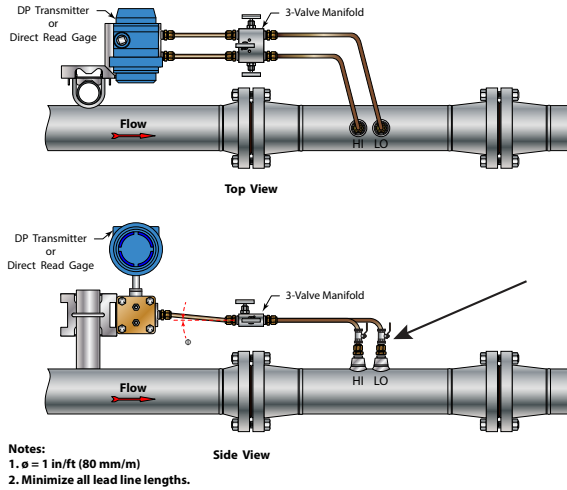

Figure 3: Typical horizontal installation for gas

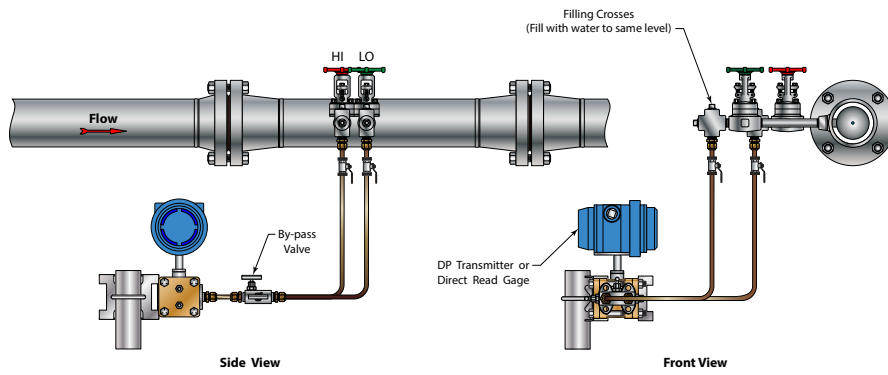

Figure 4: Typical horizontal installation for steam

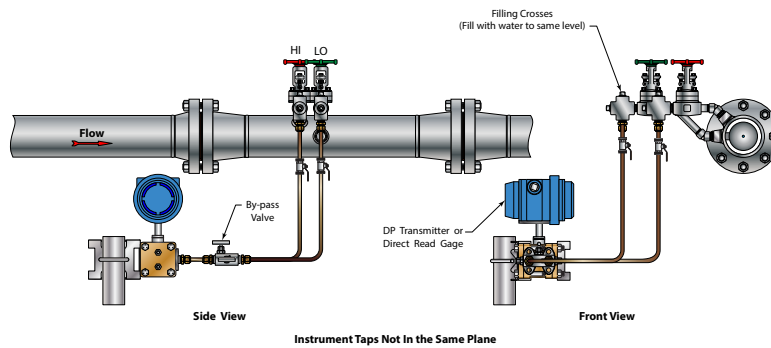

Figure 5: Optional horizontal installation for steam (instrument taps not in the same plane)

NOTE: See "Selecting a Mounting Location" on page 7 for additional information.

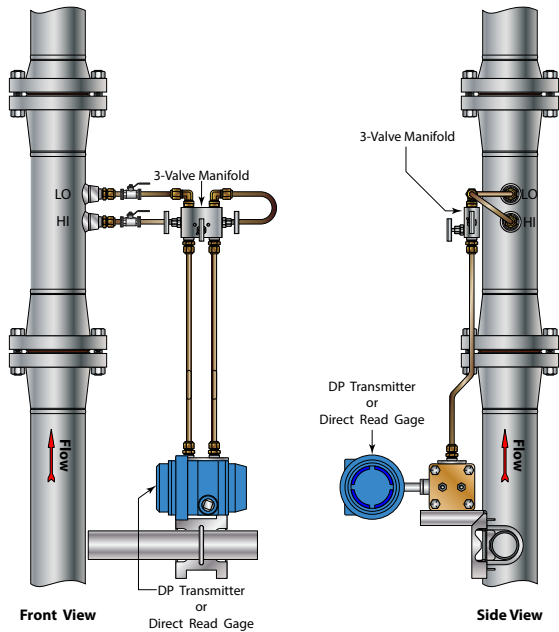

Figure 6: Typical vertical installation for liquid

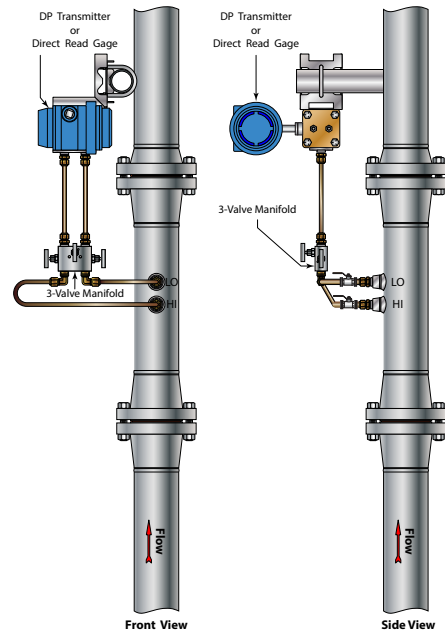

Figure 7: Typical vertical installation for gas

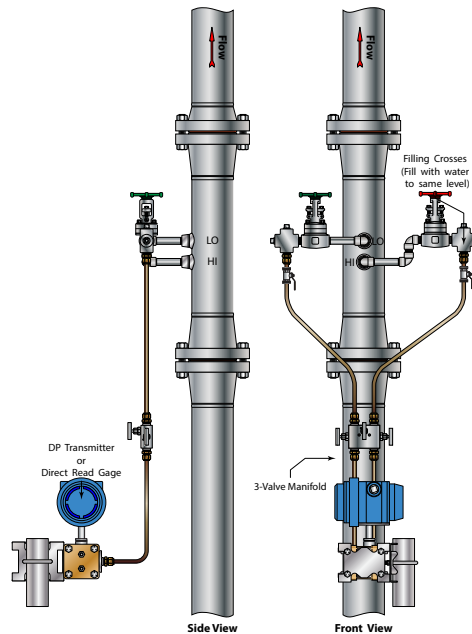

Figure 8: Typical Vertical Installation for Steam

Line Installation

All flanged Venturi flow elements require a gasket between the process line connection and the mating flange. Select gaskets that match the pressure rating of the Venturi flanges and resist corrosive attack of the process fluid.

Before completing the bolting process, be sure that the gaskets are properly centered so that protrusion into the pipe opening is minimized. Misalignment may cause added flow turbulence. Bolt the element in line with suitable hardware using recommended bolt torques for the type and class rating of the flanges.

Torque all models per ANSI flange ratings. Tighten the flange bolts in a “star” pattern to avoid localized stress on the gaskets.

CAUTION DO NOT EXCEED SPECIFIED TORQUE!

Differential Pressure Connections

The high pressure connection is always on the upstream side of the flow direction arrow and the low pressure connection on the downstream side. Fittings used must be able to withstand the process temperature and pressure conditions, as well as provide proper corrosion resistance. Refer to the literature supplied with the secondary instrument for connections to the high and low ports. All fitting threads should be coated with a process-compliant thread sealant prior to tightening. Once tightened, torque mark all fittings for future reference.

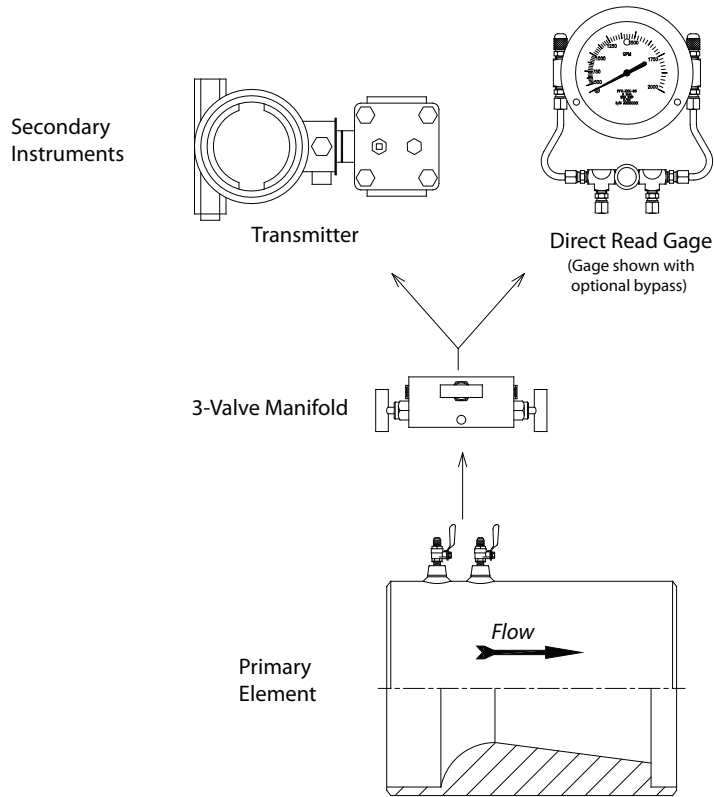

Figure 9: Secondary instrument illustration

SPECIFICATIONS

Applications:	Liquids, gases and steam
SSL – Classical (Herschel) Design / VISSL – Insert Version	
Pipe Sizes:	1/2...60 inches and larger (13...1524 mm)
Pressure & Temperature:	Varies, dependent upon materials of construction
Pressure Loss:	6% of DP maximum
Turndown Ratio:	10:1
Process Connections:	SSL; NPT, flanged, butt weld, socket weld, grooved VISSL; Insert fits between pair of flanges
Instrument Connections:	NPT, socket weld, flanged
Accuracy:	±1% of reading uncalibrated; ±0.5% of reading calibrated
Standard Beta Ratios:	0.35, 0.49, 0.63 and 0.75; Exact sizing available to provide custom beta ratios
SSM – Hydraulic Shape Design (Nozzle Type) / VISSM – Insert Version	
Pipe Sizes:	1/2...60 inches and larger (13 ...1524 mm)
Pressure & Temperature:	Varies, dependent upon materials of construction
Pressure Loss:	6% of DP maximum
Turndown Ratio:	10:1
Process Connections:	SSM; NPT, flanged, butt weld, socket weld, grooved VISSM; Insert fits between pair of flanges
Instrument Connections:	NPT, socket weld, flanged
Accuracy:	±1% of reading uncalibrated; ±0.5% of reading calibrated
Standard Beta Ratios:	0.35, 0.49, 0.63 and 0.75; Exact sizing available to provide custom beta ratios
Specifications (continued)	
LPL - Low-Loss Design (Short Form) / VILPL - Insert Version	
Pipe Sizes:	1/2...60 inches and larger (13...1524 mm)
Pressure & Temperature:	Varies, dependent upon materials of construction
Pressure Loss:	3% of DP maximum
Turndown Ratio:	10:1
Process Connections:	LPL; NPT, flanged, butt weld, socket weld, grooved VILPL; Insert fits between pair of flanges
Instrument Connections:	NPT, socket weld
Accuracy:	±3...5% of reading uncalibrated; ±0.5% of reading calibrated
Standard Beta Ratios:	-10, -20, -38, -65; Exact sizing available to provide custom beta ratios
CV Series	
Pipe Sizes:	2...16 inches and larger (51...406 mm)
Pressure:	300 psig (2070 kPa) maximum
Temperature:	250° F (120° C) maximum
Process Connections:	NPT, butt weld, flanged, grooved
Instrument Connections:	NPT
Standard Beta Ratios:	-38, -65
VBR Series	
Pipe Sizes:	1/2...2 inches (13... 51 mm)
Pressure:	400 psig (2756 kPa) maximum
Temperature:	250° F (120° C) maximum
Process Connections:	FNPT, socket/sweat
Instrument Connections:	NPT
Standard Beta Ratios:	-10, -20, -38, -65

Control. Manage. Optimize.

PRESO is a registered trademark of Badger Meter, Inc. Other trademarks appearing in this document are the property of their respective entities. Due to continuous research, product improvements and enhancements, Badger Meter reserves the right to change product or system specifications without notice, except to the extent an outstanding contractual obligation exists. © 2015 Badger Meter, Inc. All rights reserved.

www.badgermeter.com

The Americas | Badger Meter | 4545 West Brown Deer Rd | PO Box 245036 | Milwaukee, WI 53224-9536 | 800-876-3837 | 414-355-0400
México | Badger Meter de las Americas, S.A. de C.V. | Pedro Luis Ogazón N°32 | Esq. Angelina N°24 | Colonia Guadalupe Inn | CP 01050 | México, DF | México | +52-55-5662-0882
Europe, Middle East and Africa | Badger Meter Europa GmbH | Nurtinger Str 76 | 72639 Neuffen | Germany | +49-7025-9208-0
Europe, Middle East Branch Office | Badger Meter Europe | PO Box 341442 | Dubai Silicon Oasis, Head Quarter Building, Wing C, Office #C209 | Dubai / UAE | +971-4-371 2503
Czech Republic | Badger Meter Czech Republic s.r.o. | Maříkova 2082/26 | 621 00 Brno, Czech Republic | +420-5-41420411
Slovakia | Badger Meter Slovakia s.r.o. | Racianska 109/B | 831 02 Bratislava, Slovakia | +421-2-44 63 83 01
Asia Pacific | Badger Meter | 80 Marine Parade Rd | 21-06 Parkway Parade | Singapore 449269 | +65-63464836
China | Badger Meter | 7-1202 | 99 Hangzhong Road | Minhang District | Shanghai | China 201101 | +86-21-5763 5412