

Ordering Code

Double Acting Actuator

HP 050-DA
 : Double Acting Configuration
 : Cylinder Diameter

Single Acting Actuator

HP 075-S8-C
 : Fail Position { C : Closed
 O : Open
 : Spring set (S8, S9, S10...)
 : Cylinder Diameter



PNEUMATIC ACTUATOR HP - SERIES

Rack & Pinion and Scotch Yoke Design
Double Acting / Spring Return Design



HKC Co., Ltd.

5RA-503, 674-3 Sunggok-Dong, Danwon-Gu, Ansan-Shi
 Kyonggi-Do, Republic of Korea (425-836)
 Tel : 82-31-488-8266
 Fax : 82-31-488-8269
 Internet : <http://www.hkcon.co.kr>
 E-mail : hkcon@hkcon.co.kr



Hologram shall be put on all products manufactured in the factory.

Quarter turn Actuator — Single Acting and Double Acting



Compact
Lightweight
Reliable
Efficient



Introduction

HP series pneumatic actuators are specifically designed to respond to your demanding needs on automation valve market. We can provide a wide range of torque outputs to suit quarter turn ball, butterfly, plug valves and dampers for complete valve automation solutions. The latest manufacturing technologies have been operated in order to supply a high quality and cycle-life on HP series. Our extensive inventory & engineering capabilities allow us to provide reliable and safety product to our customer with satisfaction.

Specification

- **Pressure Range**
 - Max working pressure : 10 Bar
 - Double Acting : 2.5 Bar ~ 8 Bar
 - Single Acting : 2.5 Bar ~ 8 Bar
- **Temperature Range**
 - Standard : -20 ~ 80 °C
 - Option : -35 ~ 80 °C
-20 ~ 150 °C
- **Movement**
 - 90 Degree standard adjustable -5~+5 Degree
- **Lubrication**
 - All moving parts are lubricated for life-long cycle of the actuator at factory
- **Cycle Life**
 - 1,000,000 Operations

Features

- **Body**

Extruded Aluminum alloy body is hard anodized to protect internal and external corrosion ,also reduce piston friction for a long cycle life
- **Indicator**

A disc open / close indicator is standard on all models
- **Travel Stops**

External travel stops adjust -5 ~ + 5 degree in both open and close position easily
- **End Caps**

Die cast aluminum end caps is coated with polyester to provide maximum resistance against potentially corrosive elements
- **Spring**

High tensile spring sets are consisted of strength alloy steel to provide high performance in fail safe and emergency shut down operations
- **Pinion Shaft**

Alloy steel pinion is electroless nickel plated in order to reduce friction , provide maximum wear resistance and protect against corrosion under severe conditions
- **Piston Guides**

Self lubricating (Polypropylene + GF) piston guides provide high trust , stability
- **Piston Seals**

NBR rubber pinion seals provide trouble free operation at standard temperature ranges , viton seals are available for higher or lower temperature extremes
- **Piston**

Diecasted aluminum dual piston are fitted with high quality seals and guides , providing high ratio output torques , input air pressure. Twin rack and pinion & scotch yoke design a constant torque on all models

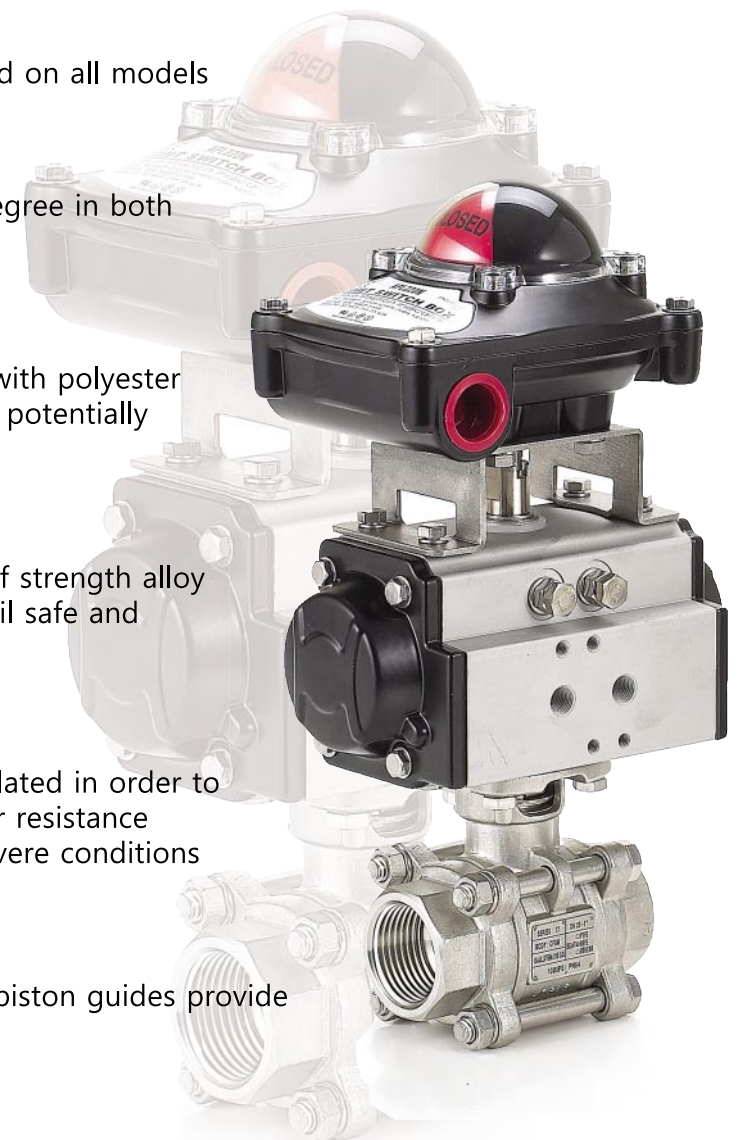

Torque Diagram (HP35~HP210)

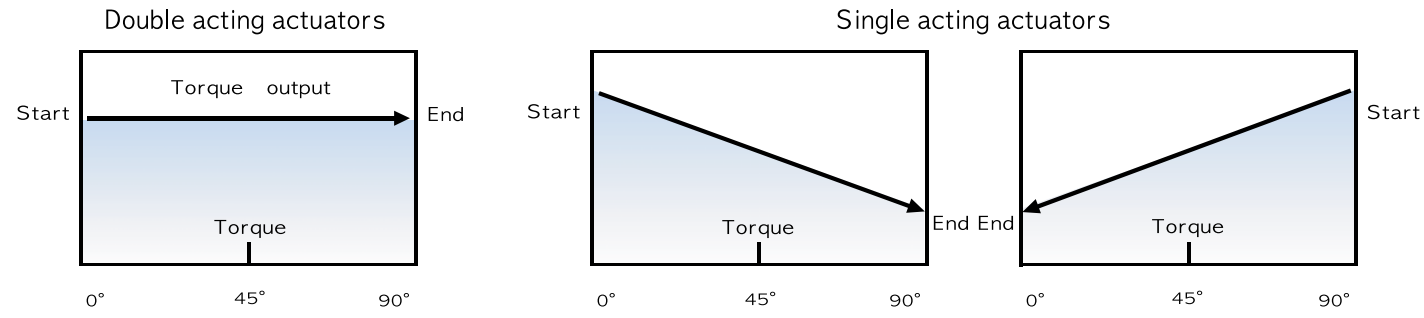

Double Acting Operation

1. Apply an air pressure to Port A and then the piston(s) are apart.
2. Turn the drive shaft counterclockwise.
3. Air volume exhausts through Port B

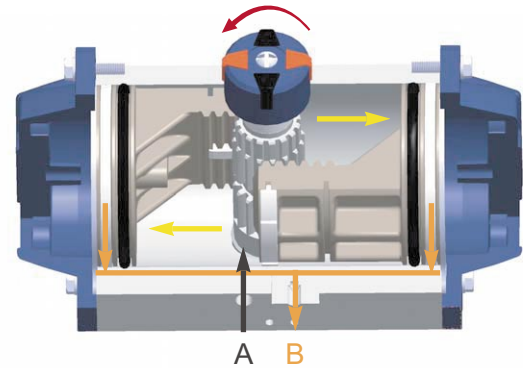

Counterclockwise

1. Apply an air pressure to Port B and then the piston(s) are together.
2. Turn the drive shaft clockwise as the air.

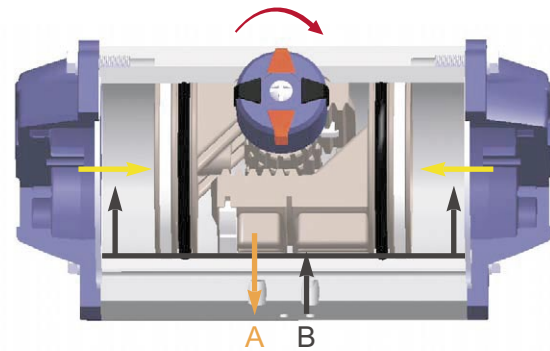

Clockwise

Single Acting Operation

1. Apply an air pressure to Port A and then the piston(s) are apart.
2. The springs are compressed after that the drive shaft counterclockwise.
3. Air volume exhausts through Port B.

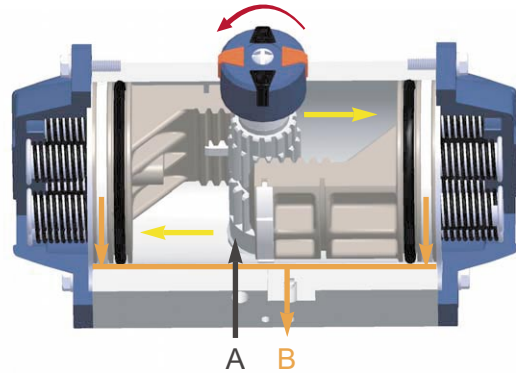

Counterclockwise

1. Exhaust the air pressure from Port A.
2. Allows stored power of the springs to piston(s) inward.
3. Turn the shaft clockwise.
4. Air volume get through Port B.

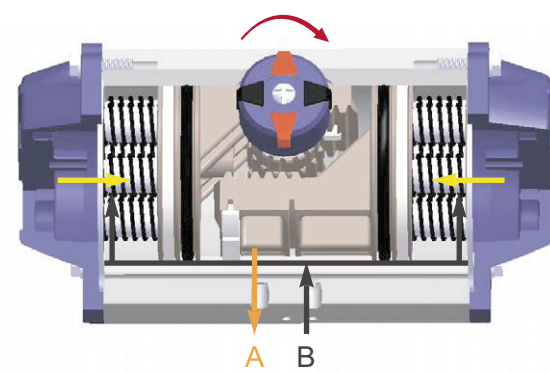

Clockwise

※ When air fail to counterclockwise is required , the pistons must be inverted.

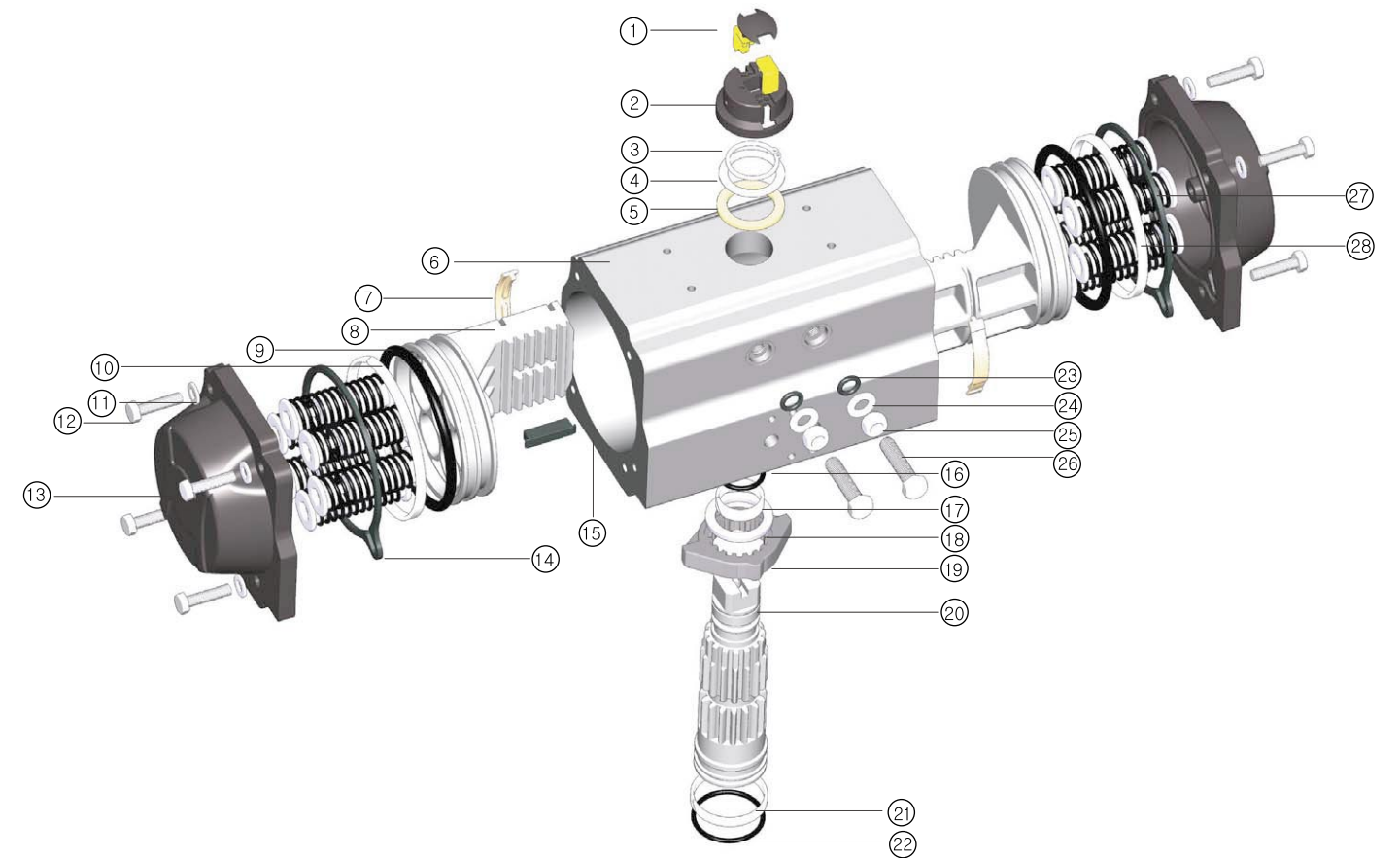

Part And Materials

PART NO	UNIT Q'TY	PART DESCRIPTION	STANDARD MATERIAL	CORROSION PROTECTION	OPTIONAL MATERIAL
1	4	Position indicator	Polypropylene +GF	-----	-----
2	1	Position indicator holder	Polypropylene +GF	-----	-----
3	1	Spring clip(pinion)	Stainless Steel	HP160,200 Nickel plated	-----
4	1	Thrust washer(pinion)	Stainless Steel	-----	-----
5	1	Thrust bearing(pinion)	Polyphthalamide	-----	-----
6	1	Body	Extruded Aluminium alloy	Hard anodized	-----
7	2	Bearing(piston back)	Polyphthalamide	-----	-----
8	2	Piston	Die Cast Aluminium	Hard anodized	-----
9	2	"O" Ring(piston)	Nitrile (NBR70)	-----	Viton SiliconViton
10	2	Bearing(piston head)	Polyphthalamide	-----	-----
11	8	Cap bolt washer	Stainless Steel	-----	-----
12	2	Cap bolt(end cap)	Stainless Steel	-----	-----
13	2	Right and left end cap	Die Cast Aluminium	Chromate + Polyester coated	-----
14	2	"O" Ring(end cap)	Nitrile (NBR70)	-----	Viton SiliconViton
15	2	Piston guide	Polypropylene +GF	-----	-----
16	1	"O" Ring(pinion top)	Nitrile (NBR70)	-----	Viton SiliconViton
17	1	Bearing(piston top)	Nylon 46	-----	-----
18	1	Thrust bearing(pinion)	Polyphthalamide	-----	-----
19	1	Open.Close cam(stop arrangement)	Stainless Steel	-----	-----
20	1	Drive shaft	Steel alloy	Nickel planted	-----
21	1	Bearing(piston bottom)	Nylon 46	-----	-----
22	1	"O" Ring(pinion bottom)	Nitrile (NBR70)	-----	Viton SiliconViton
23	1	"O" Ring(stop screw)	Nitrile (NBR70)	-----	Viton SiliconViton
24	2	Stop bolt washer	Stainless Steel	-----	-----
25	2	Stop nut	Stainless Steel	-----	-----
26	2	Stop bolt	Stainless Steel	-----	-----
27	min.5/max.12	Spring(cartridge)	High alloy Spring Steel	Epoxy coated	-----
28	1	Spring holder	Polypropylene +GF	-----	-----

Torque Diagram (HP 211 & HP 212)

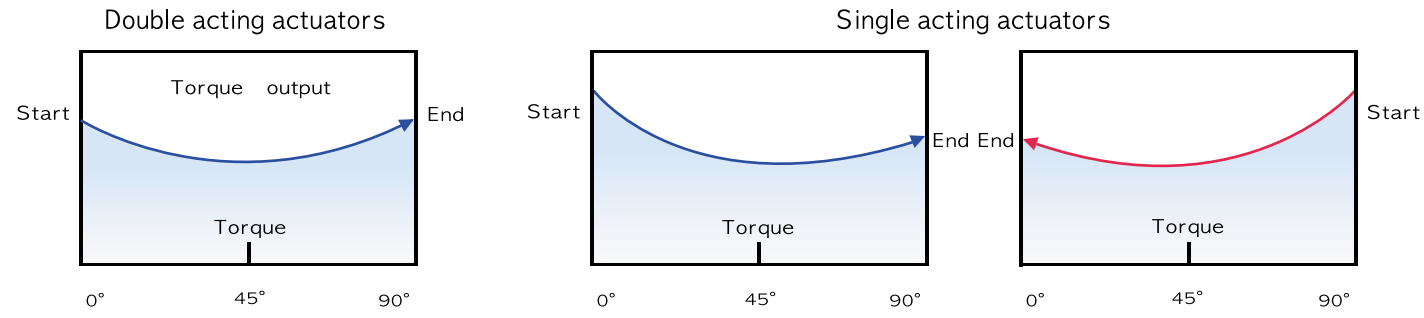

Double Acting Operation

1. Apply an air pressure to Port A and then the piston(s) are apart.
2. Turn the drive shaft counterclockwise.
3. Air volume exhausts through Port B

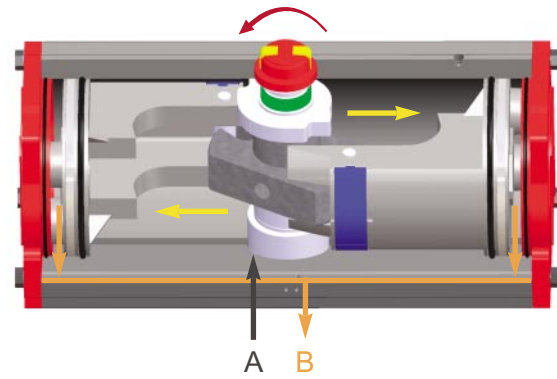

Counterclockwise

1. Apply an air pressure to Port B and then the piston(s) are together.
2. Turn the drive shaft clockwise as the air.

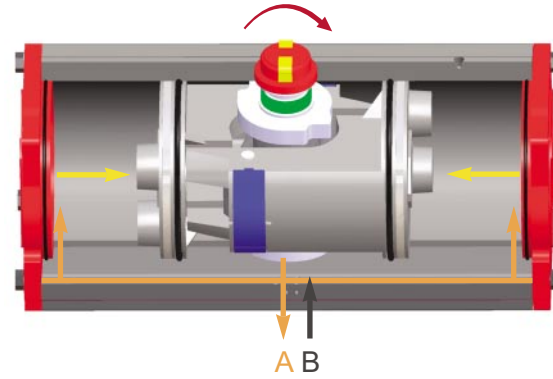

Clockwise

Single Acting Operation

1. Apply an air pressure to Port A and then the piston(s) are apart.
2. The springs are compressed after that the drive shaft counterclockwise.
3. Air volume exhausts through Port B.

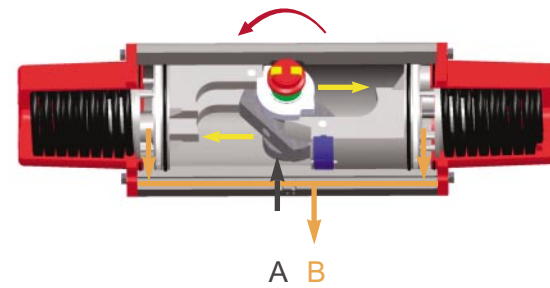

Counterclockwise

1. Exhaust the air pressure from Port A.
2. Allows stored power of the springs to piston(s) inward.
3. Turn the shaft clockwise.
4. Air volume get through Port B.

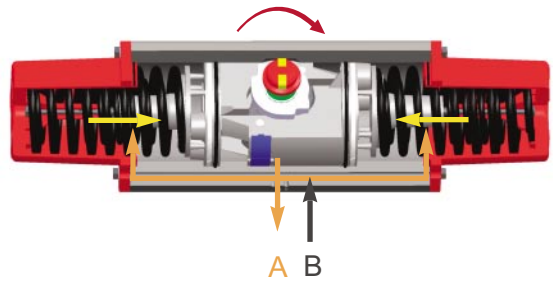

Clockwise

※ When air fail to counterclockwise is required , the pistons must be inverted.

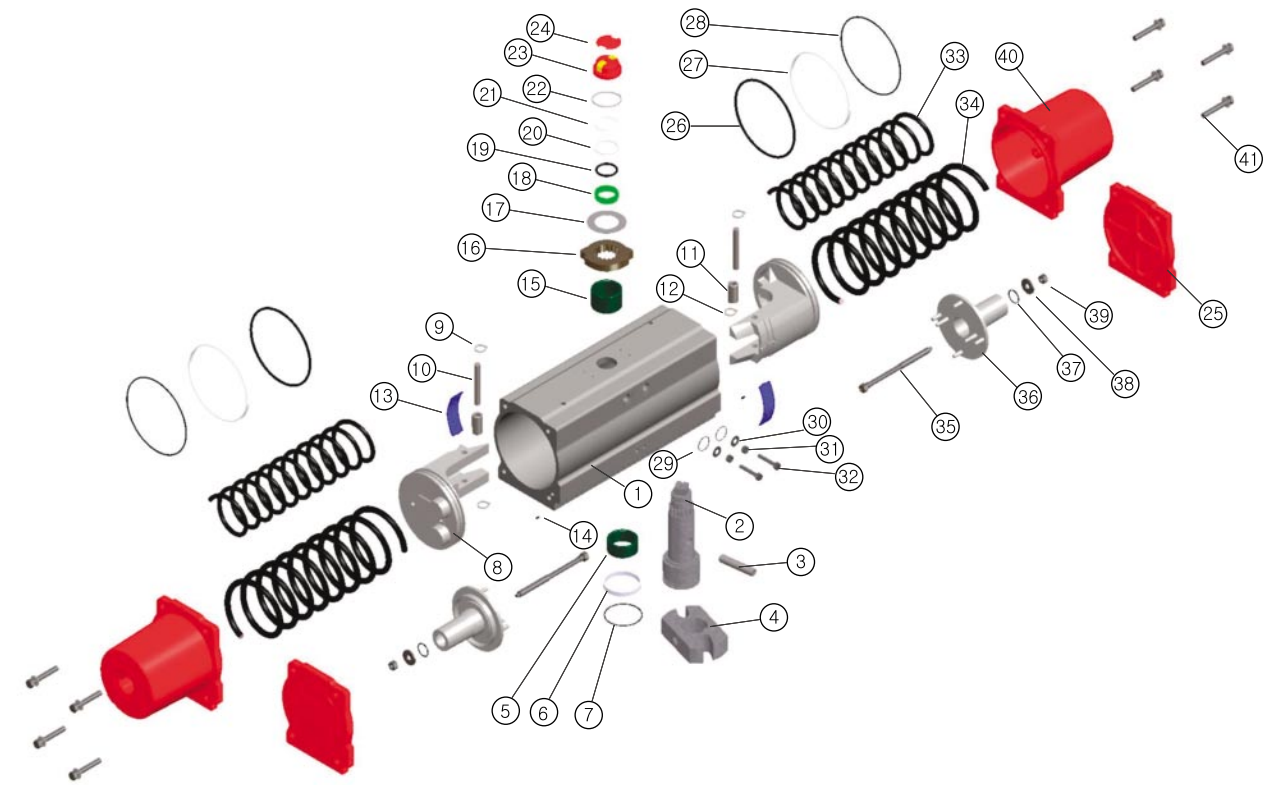

Part and Material

PART NO	UNIT Q'TY	PART DESCRIPTION	STANDARD MATERIAL	PART NO	UNIT Q'TY	PART DESCRIPTION	STANDARD MATERIAL
1	1	Cylinder Body	Aluminum Alloy	22	5	Snap Ring	Stainless Steel
2	1	Drive Shaft	Steel Alloy	23	1	Indicator	ABS
3	1	Yoke Pin	Steel	24	1	Indicator Holder Cover	ABS
4	1	Yoke	Steel	25	2	Double Acting Cover	Aluminum
5	1	Bottom Spacer	Nylon	26	2	Piston O-Ring	NBR
6	1	Stem Bottom Bearing	Stainless Steel	27	3	Piston Head Bearing	PTFE
7	1	Stem Bottom O-Ring	NBR	28	2	Cover O-Ring	NBR
8	2	Piston	Aluminum	29	2	Stop Bolt O-Ring	NBR
9	2	Snap Ring	Stainless Steel	30	2	Stop Bolt Washer	Stainless Steel
10	1	Roller Pin	Steel	31	2	Stop Bolt Nut	Stainless Steel
11	1	Shaft	Steel	32	2	Stop Bolt	Stainless Steel
12	2	Snap Ring	Stainless Steel	33	1 or 2	Inner Spring	Spring Steel
13	3	Piston Back Bearing	PTFE	34	1 or 2	Outer Spring	Spring Steel
14	2	Hole Sealant	NBR	35	1 or 2	Spring Bolt	Stainless Steel
15	1	Top Spacer	Nylon	36	1 or 2	Spring Retainer	Aluminum
16	1	OCT Cam	Steel	37	1 or 2	Spring O-Ring	NBR
17	1	Stem Thrust Bearing	Stainless Steel	38	1 or 2	Spring Washer	Steel
18	1	Stem Top Bearing	Stainless Steel	39	1 or 2	Spring Nut	Stainless Steel
19	1	Stem Top O-Ring	NBR	40	2	Spring Return Cover	Aluminum
20	1	Teflon Washer	PTFE	41	8	Cover Bolt	Stainless Steel
21	1	Stem Thrust Washer	Stainless Steel	42			

Torque Data

Double Acting Torque Ratings In Nm. Table with columns for Model, AIR SUPPLY (2.5Bar to 8Bar), and torque values. Includes models HP 35 through HP 210.

Single Acting Torque Ratings In Nm. Large table with columns for AIR SUPPLY, Actuator Spring, Model, Set, and torque ratings for models HP 50S, HP 63S, HP 66S, HP 75S, HP 88S, HP 100S, and HP 115S.

Single Acting Torque Ratings In Nm. Detailed table with columns for AIR SUPPLY, Actuator Spring, Model, Set, and torque ratings for models HP 125S, HP 145S, HP 160S, HP 180S, HP 200S, and HP 210S.

Pneumatic Scotch Yoke Actuators(HP211, HP212)

Double Acting Torque (Nm) and Single Acting Torque (Nm)

Summary tables for Double Acting Torque and Single Acting Torque for HP-211 and HP-212 actuators at 4.2 Bar, 5.6 Bar, and 7 Bar.

Air Consumption

- Double Acting Actuator

Unit: Liter (ℓ)

Model	Volume	2.5 Bar	3 Bar	3.5 Bar	4 Bar	4.5 Bar	5 Bar	5.5 Bar	6 Bar	7 Bar	8 Bar
HP - 35	0.2	0.7	0.8	0.9	1.0	1.1	1.2	1.3	1.4	1.6	1.8
HP - 50	0.3	1.1	1.2	1.4	1.5	1.7	1.8	2.0	2.1	2.4	2.7
HP - 63	0.5	1.8	2.0	2.3	2.5	2.8	3.0	3.3	3.6	4.1	4.6
HP - 66	0.5	1.8	2.0	2.3	2.5	2.8	3.0	3.3	3.6	4.1	4.6
HP - 75	0.8	2.8	3.2	3.7	4.1	4.5	4.9	5.3	5.7	6.5	7.3
HP - 88	1.3	4.6	5.3	5.9	6.6	7.3	7.9	8.6	9.3	10.6	11.9
HP - 100	1.8	6.4	7.3	8.2	9.1	10.1	11.0	11.9	12.8	14.6	16.5
HP - 115	3.0	10.6	12.2	13.7	15.2	16.8	18.3	19.8	21.4	24.4	27.5
HP - 125	3.8	13.5	15.4	17.4	19.3	21.2	23.3	25.1	27.0	30.9	34.8
HP - 145	6.2	22.0	25.2	28.3	31.5	34.6	37.8	41.0	44.1	50.5	56.8
HP - 160	7.3	25.9	29.6	33.4	37.1	40.8	44.5	48.2	52.0	59.4	66.9
HP - 180	11.2	39.8	45.5	51.2	56.9	62.6	68.3	74.0	79.7	91.1	102.6
HP - 200	15.4	54.7	62.5	70.4	78.2	86.1	93.9	101.8	109.6	125.3	141.0
HP - 210	23.8	84.5	96.6	108.7	120.9	133.0	145.1	157.3	169.4	193.7	218.0
HP - 211	19.1	67.8	77.5	87.3	97.0	106.7	116.5	126.2	136.0	155.4	174.9
HP - 212	29.6	105.1	120.1	135.2	150.3	165.4	180.5	195.6	210.7	240.9	271.1

- Single Acting Actuator

Model	Volume	2.5 Bar	3 Bar	3.5 Bar	4 Bar	4.5 Bar	5 Bar	5.5 Bar	6 Bar	7 Bar	8 Bar
HP - 50S	0.1	0.4	0.4	0.5	0.5	0.6	0.6	0.7	0.7	0.8	0.9
HP - 63S	0.2	0.7	0.8	0.9	1.0	1.1	1.2	1.3	1.4	1.6	1.8
HP - 66S	0.2	0.7	0.8	0.9	1.0	1.1	1.2	1.3	1.4	1.6	1.8
HP - 75S	0.3	1.1	1.2	1.4	1.5	1.7	1.8	2.0	2.1	2.4	2.7
HP - 88S	0.5	1.8	2.0	2.3	2.5	2.8	3.0	3.3	3.6	4.1	4.6
HP - 100S	0.7	2.5	2.8	3.2	3.6	3.9	4.3	4.6	5.0	5.7	6.4
HP - 115S	1.2	4.3	4.9	5.5	6.1	6.7	7.3	7.9	8.5	9.8	11.0
HP - 125S	1.5	5.3	6.1	6.9	7.6	8.4	9.1	9.9	10.7	12.2	13.7
HP - 145S	2.4	8.5	9.7	11.0	12.2	13.4	14.6	15.9	17.1	19.5	22.0
HP - 160S	3.1	11.0	12.6	14.2	15.7	17.3	18.9	20.5	22.1	25.2	28.4
HP - 180S	4.3	15.3	17.5	19.6	21.8	24.0	26.2	28.4	30.6	35.0	39.4
HP - 200S	5.9	20.9	23.9	27.0	30.0	33.0	36.0	39.0	42.0	48.0	54.0
HP - 210S	7.8	27.7	31.7	35.6	39.6	43.6	47.6	51.5	55.5	63.5	71.4
HP - 211S	5.1	18.1	20.7	23.3	25.9	28.5	31.1	33.7	36.3	41.5	46.7
HP - 212S	9.6	34.1	39.0	43.9	48.8	53.7	58.5	63.4	68.3	78.1	87.9

Actuator Weight

Unit: kg

Model	HP - 35	HP - 50	HP - 63	HP - 66	HP - 75	HP - 88	HP - 100	HP - 115
Weight (Double Acting)	0.54	1.16	1.68	2.4	3	4.3	6	9
Spring(1ea)	N/A	0.009	0.017	0.021	0.033	0.056	0.078	0.121

Model	HP - 125	HP - 145	HP - 160	HP - 180	HP - 200	HP - 210	HP - 211	HP - 212
Weight (Double Acting)	11.3	14.1	22	26.5	38.4	46	46	71
Spring(1ea)	0.165	0.202	0.359	0.521	0.752	0.882	14.1	28.2

※ Single Acting weight = Packed Springs + Double Acting Weight

(HP-35) - Rack & Pinion Design

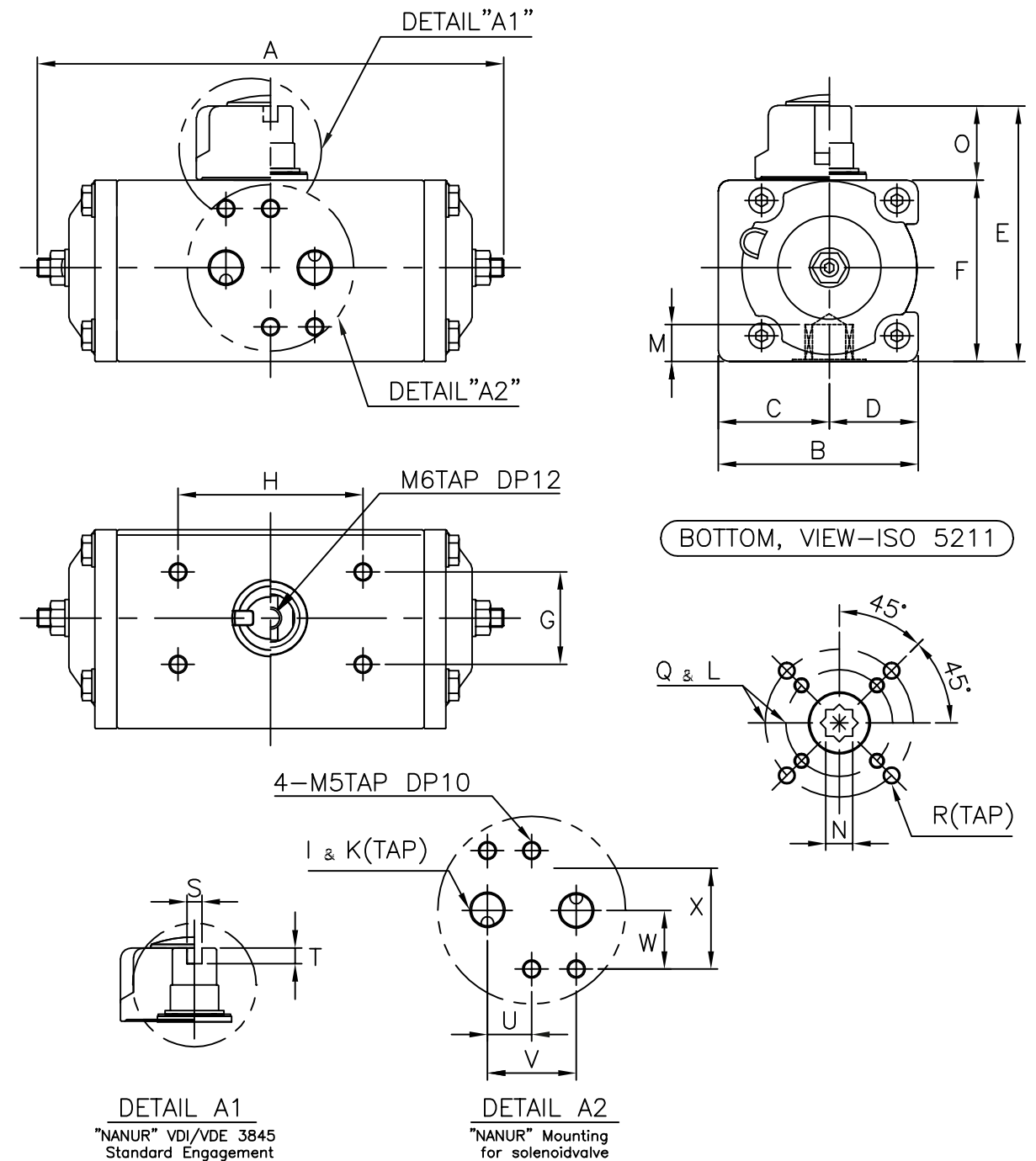

Model	Flange L (ISO5211)		A	B	C	D	E	F	G	H	I	K	O	S	T	U	V	W	X
	Q	R																	
HP - 35	F03/F05	M5/M6	126	54	30	24	69	49	25	50	PF	1/8"	20	4	4	12	24	16	32
	Φ36/Φ50	10/9																	

HP-50 ~ HP-210 - Rack & Pinion Design

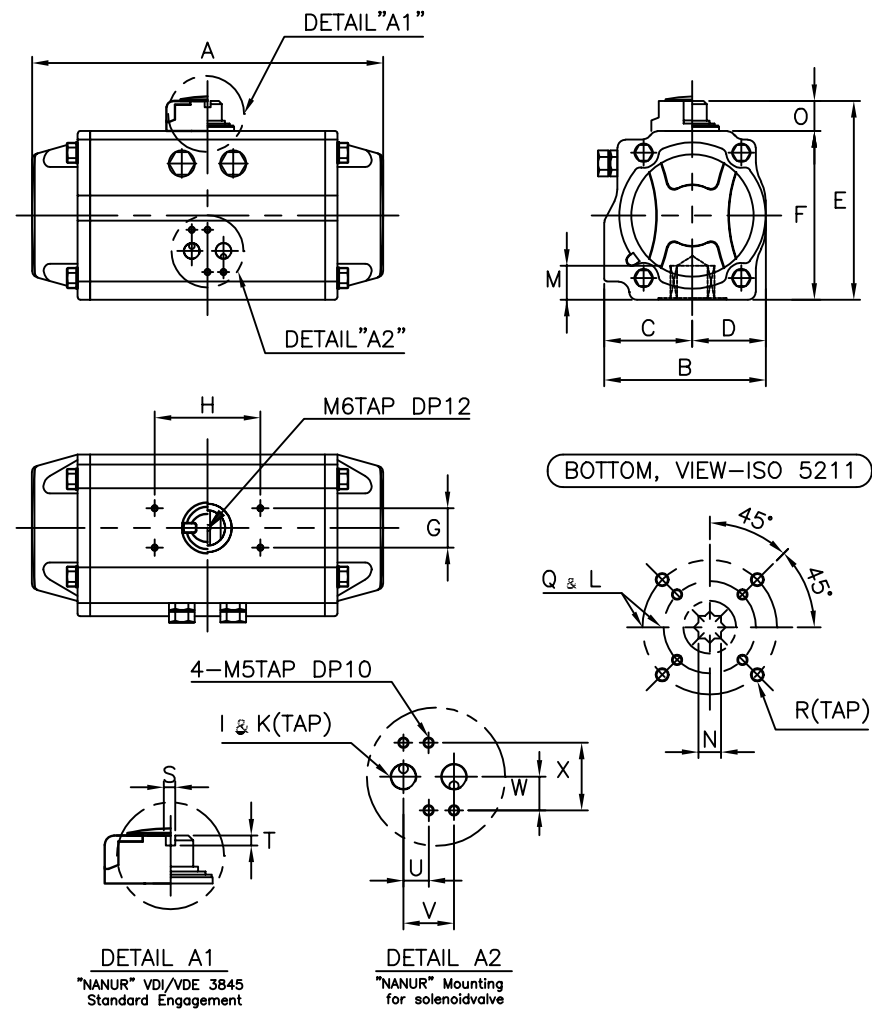

Model	Flange L (ISO5211)		A	B	C	D	E	F	G	H	I	K	O	S	T	U	V	W	X
	Q	R M/N (min)																	
HP - 50	F03/F05 Φ36/Φ50	M5/M6 14/11	144	72	42	30	93	73	30	80	PF	1/8"	20	4	4	12	24	16	32
HP - 63	F05/F07 Φ50/Φ70	M6/M8 18/14	163	85	47	38	107	87	30	80	PF	1/8"	20	4	4	12	24	16	32
HP - 66	F05/F07 Φ50/Φ70	M6/M8 18/14	202	85	47	38	107	87	30	80	PF	1/8"	20	4	4	12	24	16	32
HP - 75	F05/F07 Φ50/Φ70	M6/M8 22/17	210	96	53.5	42.5	124	104	30	80	PF	1/8"	20	4	4	12	24	16	32
HP - 88	F05/F07/F10 Φ50/Φ70/Φ102	M6/M8/M10 22/17	247	108	58.5	49.5	136	116	30	80	PF	1/8"	20	4	4	12	24	16	32
HP - 100	F05/F07/F10 Φ50/Φ70/Φ102	M6/M8/M10 22/17	268	123	67	56	148	128	30	80	PF	1/4"	20	4	4	12	24	16	32
HP - 115	F07/F10 Φ70/Φ102	M8/M10 32/22	316	141	77	64	166	146	30	80	PF	1/4"	20	4	4	12	24	16	32
HP - 125	F07/F10/F12 Φ70/Φ102/Φ125	M8/M10/M12 32/22	347	151	82	69	179	159	30	80	PF	1/4"	20	4	4	12	24	16	32
HP - 145	F10/F12 Φ102/Φ125	M10/M12 36/27	414	172	92	80	209	179	30	80/130	PF	1/4"	30	4	4	12	24	16	32
HP - 160	F10/F12 Φ102/Φ125	M10/M12 36/27	467	190	101	89	226	196	30	80/130	PF	1/4"	30	4	4	12	24	16	32
HP - 180	F10/F12 Φ102/Φ125	M10/M12 39/36	497	206	107	99	251	221	30	130	PF	1/4"	30	4	4	12	24	16	32
HP - 200	F14 Φ140	M16 39/36	555	227	116	111	277	247	30	130	PF	1/4"	30	4	4	12	24	16	32
HP - 210	F14 Φ140	M16 43/36	628	236	120	116	286	256	30	130	PF	1/4"	30	4	4	12	24	16	32

HP-211 ~ HP-212 - Scotch yoke Design

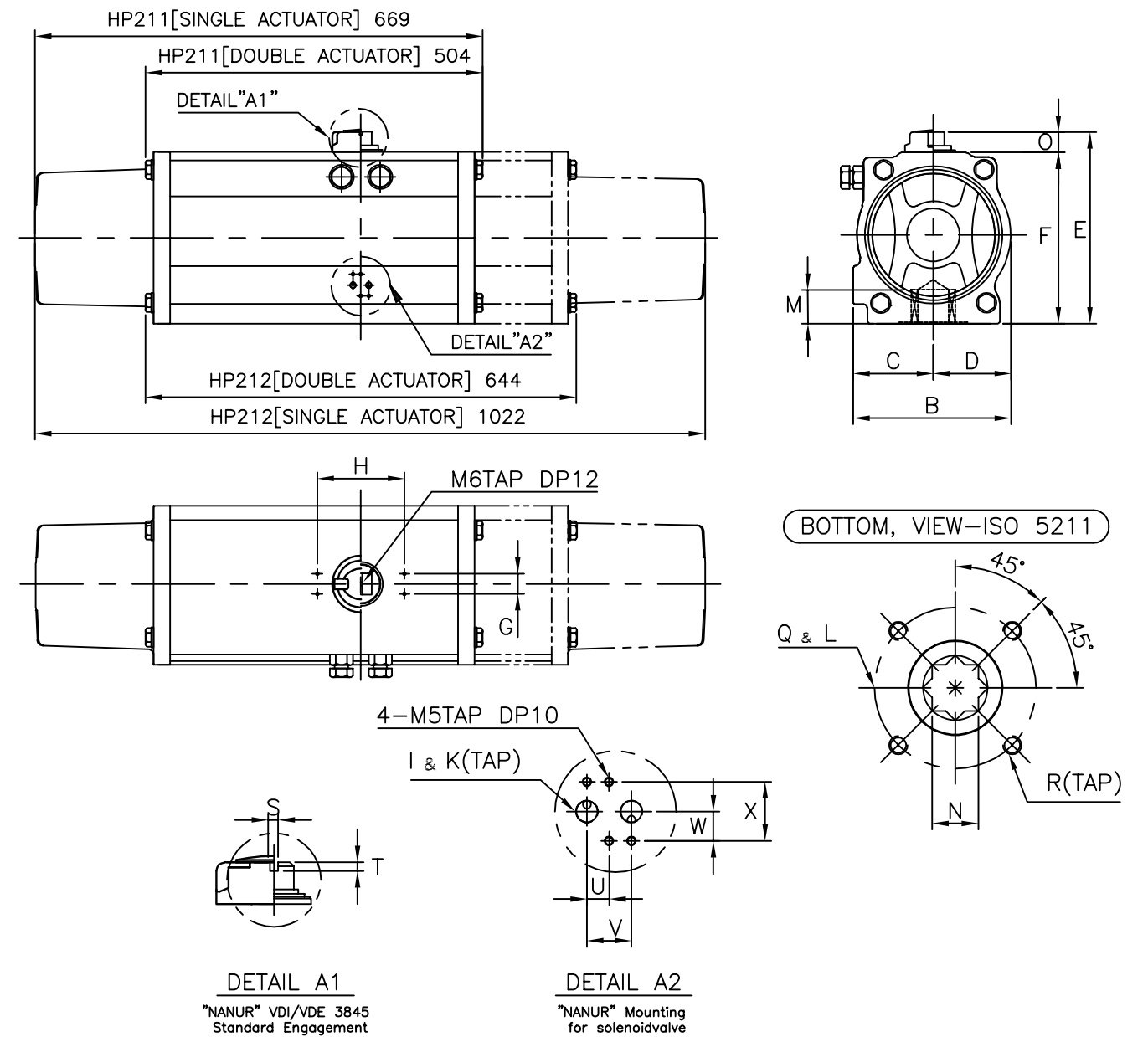

Model	Flange L (ISO5211)		A	B	C	D	E	F	G	H	I	K	O	S	T	U	V	W	X
	Q	R M/N (min)																	
HP - 211	F16	M20		236	120	116	286	256	30	130	PF	1/4"	30	4	4	12	24	16	32
	Φ165	54/46																	
HP - 212	F16	M20		236	120	116	286	256	30	130	PF	1/4"	30	4	4	12	24	16	32
	Φ165	54/46																	

- IF YOU WANT TO APPLY TO "F14(ISO5211)", PLEASE CONTACT US HKC.

Dimension - Pinion Shaft Star Adepter

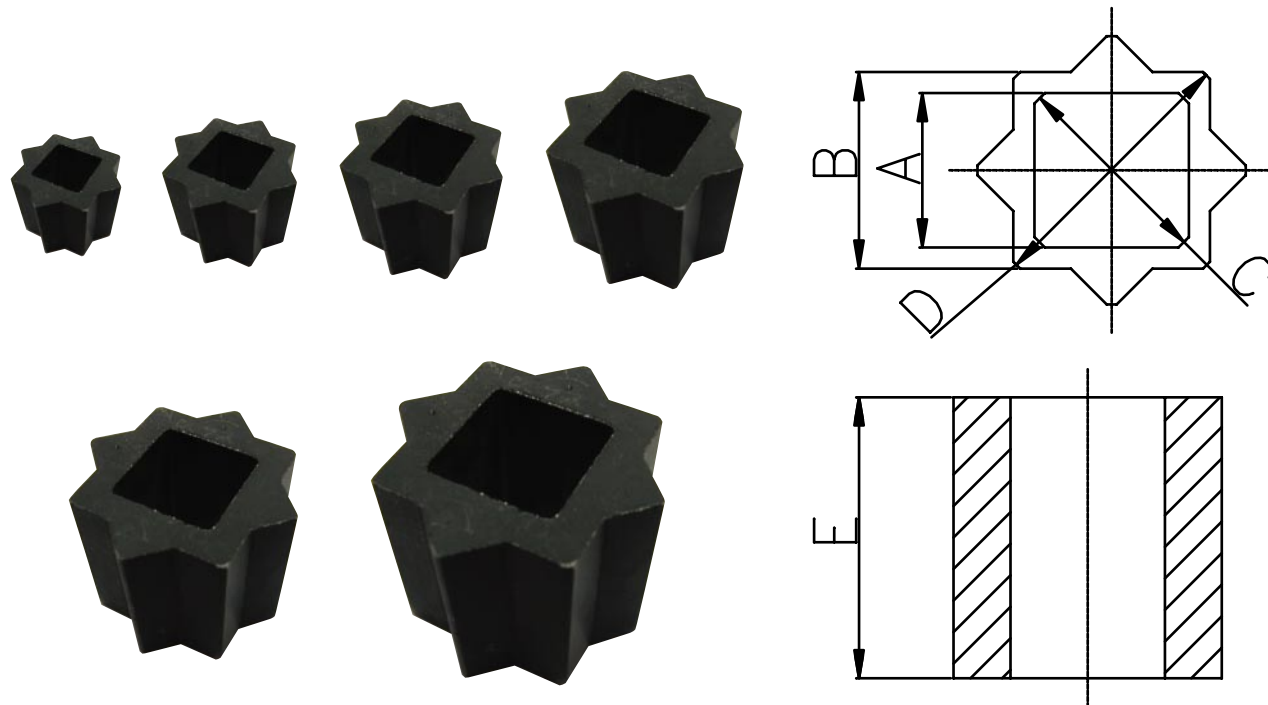

Model	A	B	C	D	E
HP - 50	9	11	13	15	14
HP - 63	11	14	14	19.1	18
HP - 66	11	14	14	19.1	18
HP - 75	14	17	19	23.1	22
HP - 88	14	17	19	23.1	22
HP - 100	14	17	19	23.1	22
HP - 115	17	22	23	29.6	32
HP - 125	17	22	23	29.6	32
HP - 145	22	27	30	36	36
HP - 160	22	27	30	36	36
HP - 180	27	36	37	48	39
HP - 200	27	36	37	48	39
HP - 210	27	36	37	48	43

Features

HGO Series is newly designed and invented for small size valve automation like ball, butterfly, plug and even dampers.

Small, light and compact design, high torque will meet your various specific requirements.

Compact and light due to high grade aluminum alloy housing. (HGO 010A)

Mounting base standard to ISO5211

Solid with O-ring system giving Weatherproof(IP67)

Self lubrication Worm shaft guides provide high trust, stability

Block and bleed valve to exhaust air



Dimension

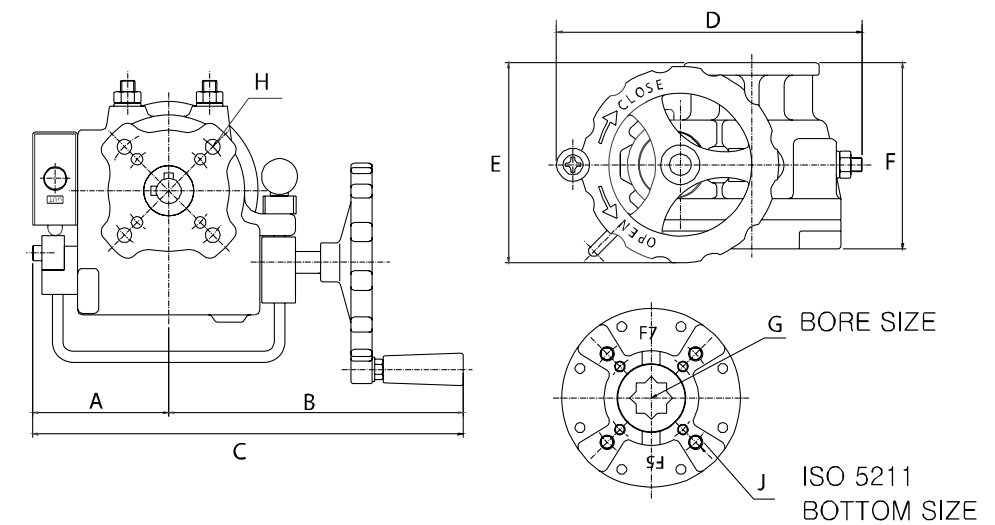

MODEL	A	B	C	D	E	F	G	H/J	Weight (kg)	Max Torque	Applicable actuators	
HGO 010A	mm	81	159	240	158	112	104	14	F05,F07	3,2	12Kgf.m 104 Lb.in	HP 35~75
	inch	3.19	6.26	9.45	6.22	4.4	4.09	0.56				
HGO 010C	mm	81	159	240	158	112	104	14	F05,F07	5,1	12Kgf.m 104 Lb.in	HP 35~75
	inch	3.19	6.26	9.45	6.22	4.4	4.09	0.56				
HGO 050C	mm	104	212	316	229	469	148	22	F10,F12	16,1	50Kgf.m 4340 Lb.in	HP 88~125
	inch	4.1	8.35	12.44	9.01	6.65	5.82	0.87				
HGO 080C	mm	104	220	324	261	204	154	27	F10,F12	17,1	80Kgf.m 6943 Lb.in	HP 125~160
	inch	4.1	8.67	12.76	10.28	8.03	6.06	1.06				
HGO 150C	mm	128	274	402	346	300	190	36	F10,F14	42,8	150Kgf.m 13019 Lb.in	HP 160~200
	inch	5.03	10.79	15.83	13.62	11.81	6.3	1.42				

※ Last alphabet in model, A means Aluminum housing, C means cast iron.