



# **SERIES 2000 ELECTRIC ACTUATORS**

**EIM CONTROLS**

 **LYNSA**  
Medición y Control  
Industrial

E-Mail: [ventas@lynsa.com](mailto:ventas@lynsa.com)  
Web : [www.lynsa.com](http://www.lynsa.com)



**ISO CERTIFIED 9001**

---

## **TABLE OF CONTENTS**

• Introduction	3
• Series 2000	4-5
• Quarter Turn Selection Guide	6
• Multi-Turn Selection Guide	7
• Motors & Spur Gears	8
• Clutch	8
• Main Drive Gears	9
• Limit Drive Assemblies	10
• M2CP - Modular Control Package	11
• M2CP - Features & Benefits	12
• M2CP - Options & Accessories	13
• Controlinc Network Control	14-15





**EIM CONTROLS**

**EIM** Controls, Inc has manufactured high quality valve actuators since 1949. We introduced CONTROLINC, the first digital control system for valve actuators, in 1985. For almost half a century, we have remained pioneers in product innovation and technical design improvement.

We design and manufacture every product to exceed user expectations of superior performance and long operating life. EIM's ISO 9001 certification testifies to our high quality today and our commitment to constant improvement in the future.

Known for rugged construction and long-term reliability EIM actuators are produced by highly skilled and dedicated people at our corporate headquarters outside of Houston, Texas.

The commitment to innovative information technology allows EIM to lead the industry in competitive application solutions and on-time delivery.

EIM's success is reinforced by our extensive distributor network. Distributors provide the resources necessary to design, install and service a project that will fulfill all customer requirements. Their expertise and after-sale service are especially important in the complex world of two-wire digital control networks.

EIM users have consistently described EIM products with one word, **QUALITY**. The final proof is always in the performance, reliability, and long life of the valve actuator. With almost 50 years of experience EIM is the expert in actuator design and manufacturing that can meet all your valve control needs today and in the future.



# SERIES 2000 ELECTRIC ACTUATOR

**Motor** options include most voltages of single phase or three phase alternating current and direct current. Motors are available with built-in thermal protection.

**Motor Gear** selections allow for speed and torque output combinations.

**Handwheel Gearset** allows user to limit the rimpull required to operate valve manually regardless of torque required.

**Transformer** is fully encapsulated and epoxy impregnated.

**Reversing Contactor** is DIN rail mounted for quick maintenance.

**Power Module (PWR)** provides transformer primary fuses and terminal strip for motor voltage.

**Terminal Board Module (TBM)** provides connection points for user wiring and transformer secondary fuses.

**Overload Relay** senses over-current to provide motor thermal protection.

**Intermediate Switch Module (ISM)** available in different options including Controlinc, Futronic modulating controls, Interposing relays, and Intermediate limit switches.

**Limit Switch Module (LSM)** allows combinations of position limit switches, torque switches, push buttons, pilot lights and selector switch.

**LED's** (light emitting diodes) are used to provide reliable service and long life.

**Torque Switch** protects the valve and actuator; in both the open and close directions.

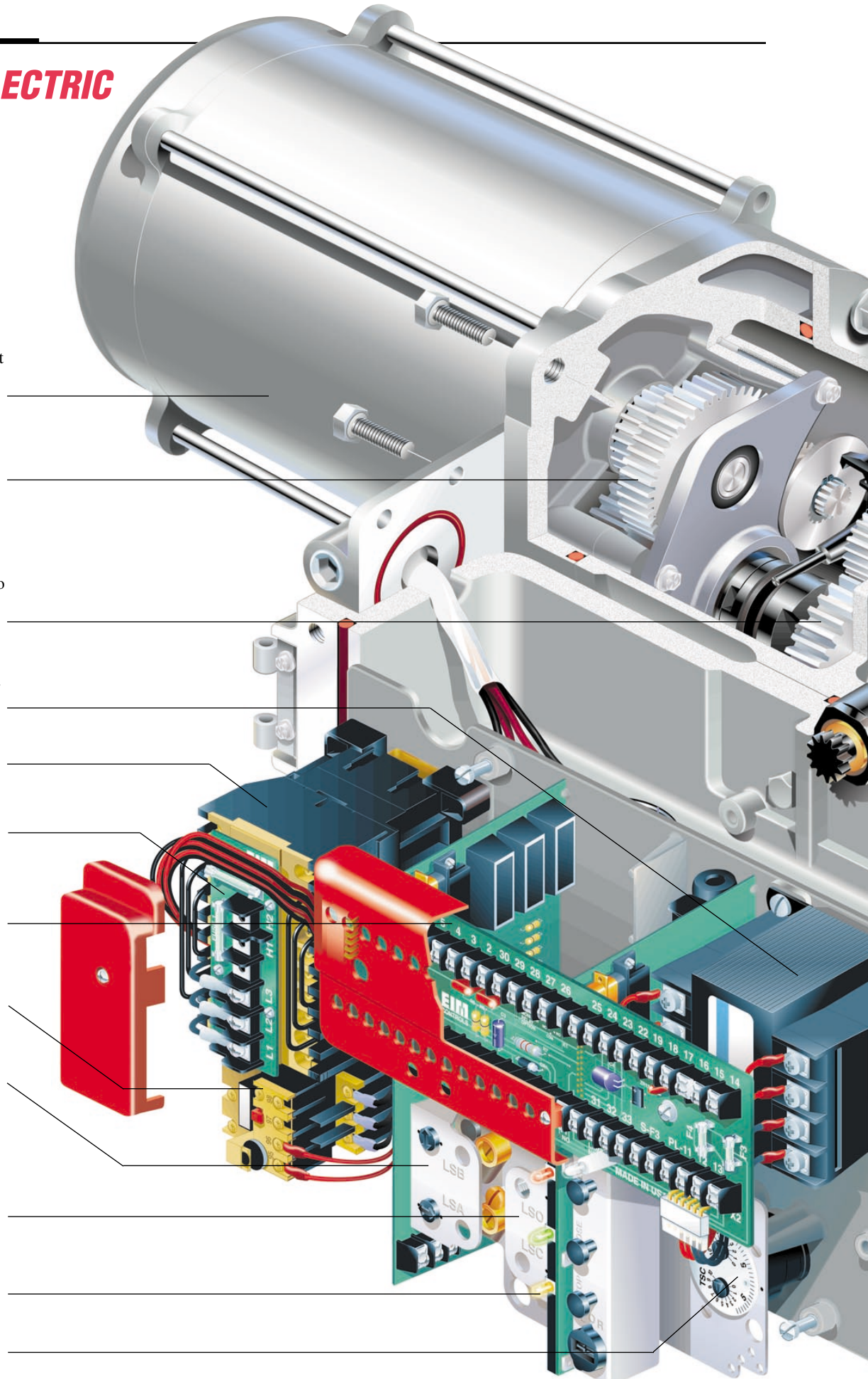

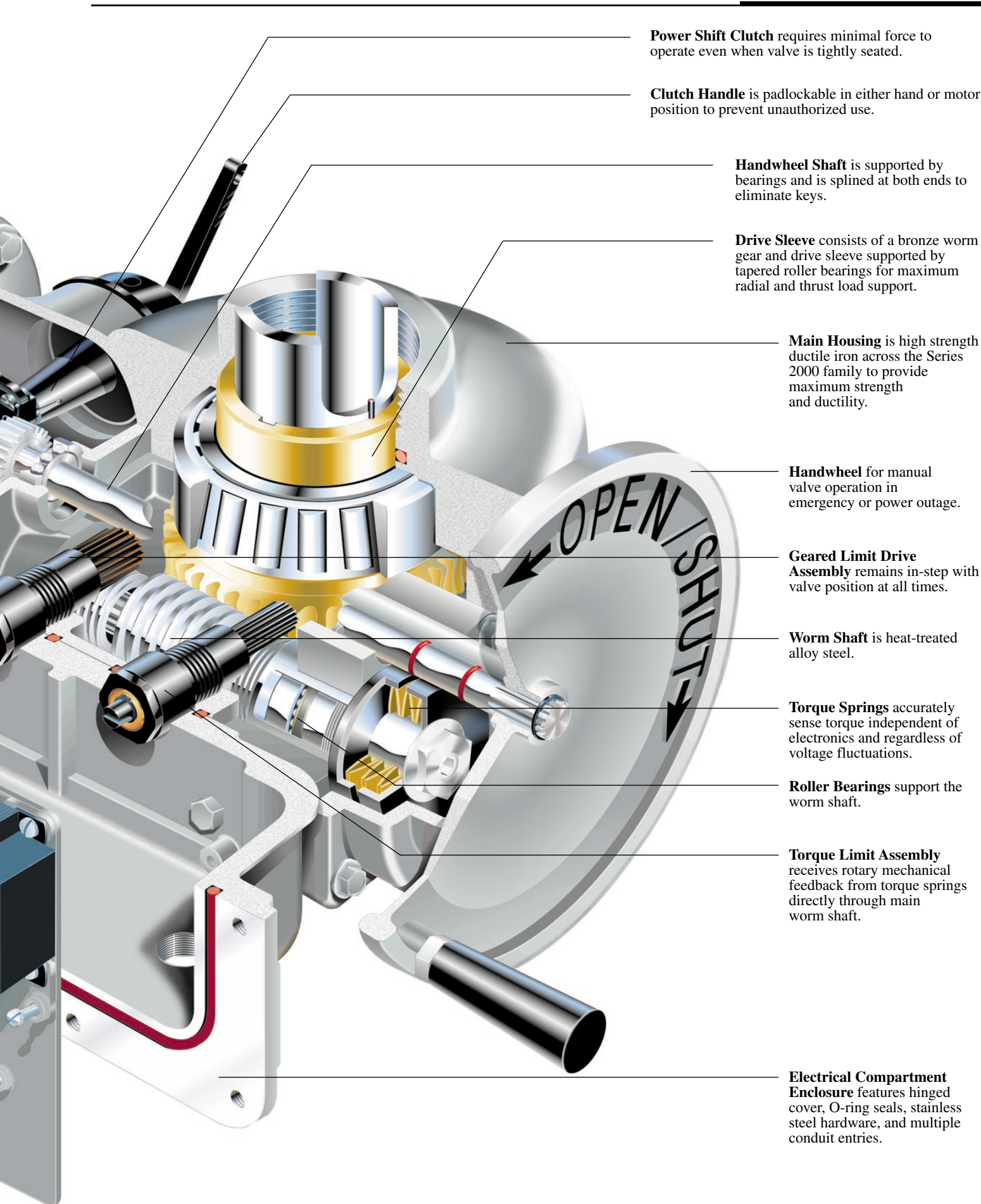

**Power Shift Clutch** requires minimal force to operate even when valve is tightly seated.

**Clutch Handle** is padlockable in either hand or motor position to prevent unauthorized use.

**Handwheel Shaft** is supported by bearings and is splined at both ends to eliminate keys.

**Drive Sleeve** consists of a bronze worm gear and drive sleeve supported by tapered roller bearings for maximum radial and thrust load support.

**Main Housing** is high strength ductile iron across the Series 2000 family to provide maximum strength and ductility.

**Handwheel** for manual valve operation in emergency or power outage.

**Geared Limit Drive Assembly** remains in-step with valve position at all times.

**Worm Shaft** is heat-treated alloy steel.

**Torque Springs** accurately sense torque independent of electronics and regardless of voltage fluctuations.

**Roller Bearings** support the worm shaft.

**Torque Limit Assembly** receives rotary mechanical feedback from torque springs directly through main worm shaft.

**Electrical Compartment Enclosure** features hinged cover, O-ring seals, stainless steel hardware, and multiple conduit entries.

# SERIES 2000 QUARTER TURN SELECTION GUIDE

**THE SERIES 2000 QUARTER TURN** electric valve actuator offers a wide range of frame sizes, horsepower ratings and output speeds readily tailored to your specific applications. EIM quarter turn products are selected by application requirements of voltage, torque, operating time, and valve shaft diameter. Actuators are designed for ball, plug, and butterfly valves as well as quarter turn damper and louver drives.

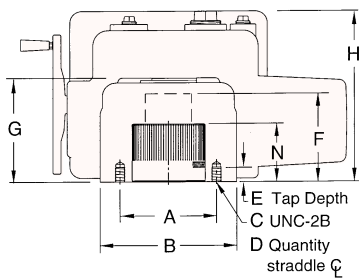
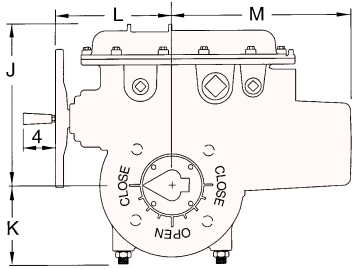

*P, Q, & R Top Mount*

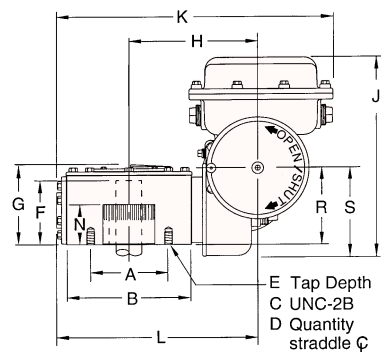
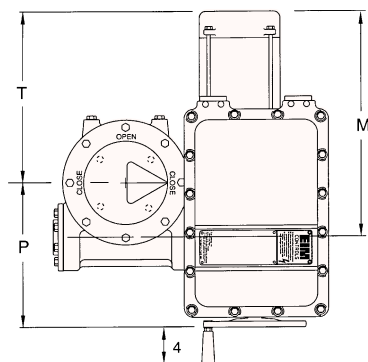

*M/MG Side Mount*

EIM QUARTER TURN								
	P	Q	R	M/MG2	M/MG3	M/MG5	M/MG7	M/MG8
<b>Torque (ft-lb)</b>	210	750	1,500	2,250	7,200	30,000	70,000	150,000
<b>Shaft (max)</b>	1.13	2.00	3.25	3.25	5.00	7.00	9.00	12.00
<b>A Bolt Circle</b>	4.00	4.95	6.50	6.50	11.75	16.00	19.00	29.00
<b>B Base O.D.</b>	4.92	5.91	8.25	9.63	13.50	18.75	22.0	32.0
<b>C UNC-2B</b>	3/8-16	1/2-13	3/4-10	3/4-10	3/4-10	11/4-7	11/4-7	11/4-7
<b>D Quantity</b>	4	4	4	4	8	8	12	12
<b>E Depth</b>	0.80	0.80	1.10	1.00	1.00	1.25	2.50	2.00
<b>F Max</b>	3.5	4.5	4.7	5.9	5.7	7.1	9.8	11.5
<b>G</b>	5.0	5.0	6.9	6.4	6.8	8.5	11.2	15.5
<b>H</b>	11.2	11.2	11.5	10.0	11.7	16.5	24.6	36.5
<b>J*</b>	8.6	8.6	8.6	15.4	15.4	15.4	17.5	30.1
<b>K</b>	4.5	4.5	5.0	22.0	24.8	33.1	44.3	65.5
<b>L</b>	7.5	7.5	8.0	16.1	18.9	27.2	38.4	54.3
<b>M</b>	17.5	17.5	19.2	22.0	22.0	22.0	29.8	40.5
<b>N</b>	2.5	3.0	3.6	3.6	5.0	7.0	9.0	11.3
<b>P</b>				12.3	15.1	18.5	22.0	39.6
<b>R</b>				5.9	6.0	6.9	7.6	12.5
<b>S</b>				6.9	6.9	6.9	7.8	14.0
<b>T</b>				17.8	14.9	11.8	15.8	17.6
<b>Weight (lbs)</b>	90	100	180	210	325	620	1,200	2,600
<b>Splined Bushing (Shaft Range)</b>	0.375 To 1.125	0.500 To 2.000	1.000 To 3.250	1.000 To 3.250	2.500 To 5.000	2.750 To 7.000	5.500 To 9.000	1 PC Drive Sleeve up to 12.000

\*Standard M2CP enclosure cover is shown. Add 3.2 inches for full MCP cover.  
Dimensions are in inches and are for reference only. Weights are approximate.

AVAILABLE VOLTAGES:	
<b>3 Phase, 60 Hz</b>	208, 230, 440, 460, 575
<b>3 Phase, 50 Hz</b>	380, 415
<b>1 Phase, 60 Hz</b>	115, 208, 230
<b>1 Phase, 50 Hz</b>	115

# SERIES 2000 MULTI-TURN SELECTION GUIDE

**THE SERIES 2000 MULTI-TURN** electric valve actuators offers a wide range of frame sizes, horsepower ratings, and output speeds. EIM multi-turn products are selected by application requirements of voltage, torque, thrust, RPM, and stem or shaft diameter. Actuators are designed for service on gate, globe, check, stop-check, and angle-check valves as well as sluice gates, weir gates, and multi-turn damper drives. EIM mounting dimensions are consistent with MSS SP-102 and ISO 5210 currently issued. Type 1000 is available to replace existing EB-000 and competitive models that require 3.250" bolt circle.

EIM MULTI-TURN MODELS							
	1000	2000	3000	4000	5000	EB-03**	EB-04**
<b>Torque (ft-lb)</b>	130	410	900	1,400	1,900	4,200	8,000
<b>Thrust (lbs)</b>	10K	30K	45K	60K	75K	140K	250K
<b>Stem (max)</b>	1.25	2.25	3.00	3.50	3.50	5.00	6.00
<b>A Bolt Circle</b>	4.000	5.500	6.500	10.000	11.750	14.000	16.000
<b>B Pilot (nom)</b>	2.312	3.750	5.000	6.000	7.000	8.499	8.999
<b>C</b>	.120	.150	.185	.185	.185	.185	.185
<b>D UNC-2B</b>	3/8-16	5/8-11	3/4-10	5/8-11	3/4-10	1-8	1 1/4-7
<b>E Quantity</b>	4	4	4	8	8	8	8
<b>F Depth</b>	0.80	1.32	1.52	0.85	0.85	2.00	2.00
<b>G</b>	4.92	7.25	8.63	11.38	13.63	16.00	18.75
<b>H</b>	5.1	7.5	8.4	15.1	15.1	15.6	16.3
<b>I</b>	5.3	7.8	8.8	15.1	15.1	13.3	15.5
<b>J</b>	1.450	2.350	3.150	3.650	3.650	5.250	6.200
<b>L</b>	1.745	2.800	3.642	none	none	5.980	6.990
<b>M</b>	1.62	2.25	3.54	3.60	3.60	7.50	9.00
<b>N</b>	0.75	0.65	0.95	0.60	0.60	2.25	2.50
<b>Bore (max)</b>	1.25	2.00	2.50	3.00	3.00	3.75	4.25
<b>NPT</b>	2"	3"	4"	4"	4"	6"	8"
<b>AA</b>	3.6	3.7	4.3	5.7	6.9	8.0	9.5
<b>AB*</b>	11.8	11.8	12.8	12.8	12.8	18.5	21.5
<b>AC</b>	8.0	8.0	8.0	9.0	9.0	21.0	24.0
<b>AD</b>	22.0	22.0	27.0	28.0	28.0	41.0	41.0
<b>AE</b>	11.2	11.2	12.1	17.8	17.8	15.0	16.5
<b>Weight (lbs)</b>	100	190	350	500	600	1,200	1,800

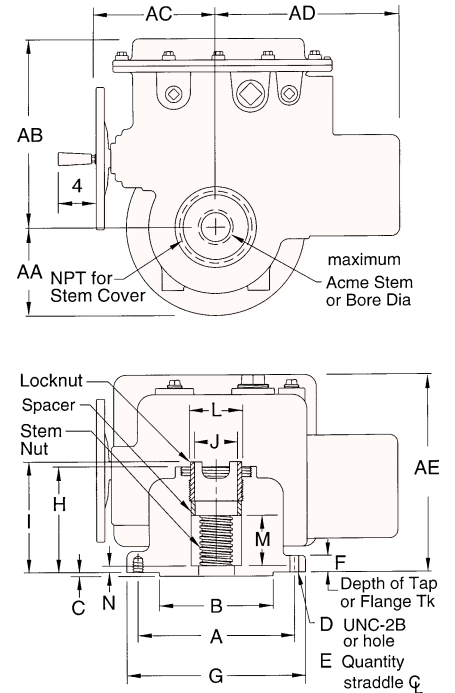

\*Standard M2CP enclosure cover is shown. Add 3.2 inches for full MCP cover.

\*\*EB Series may offer different features & specifications.

Dimensions are in inches and are for reference only. Weights are approximate.

# MOTORS & SPUR GEARS

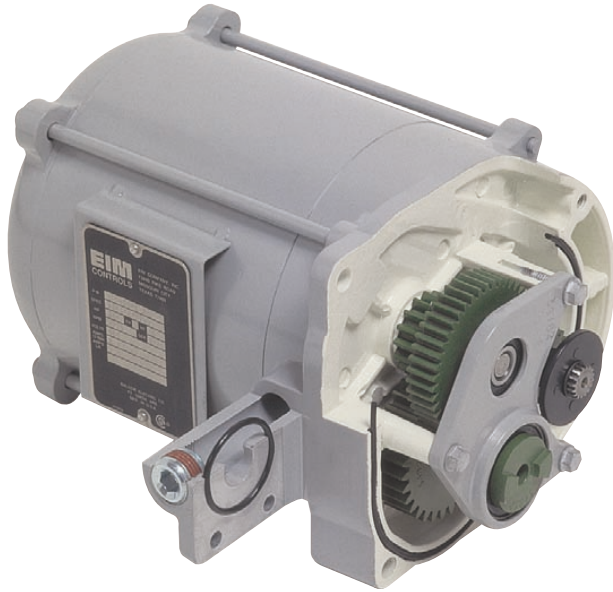

Splined Connection

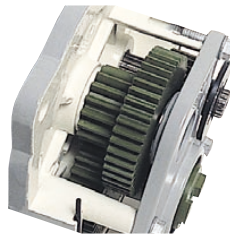

Motor Gear Assembly

- Alloy steel motor gears are spline mounted for maximum strength and ease of installation
- Gear sets are interchangeable
- Assembled in single or double-reduction ratios as required for actuating time

- A wide range of motor reduction spur gear selections offers numerous speed and torque output combinations
- Field modification for alternate torque and RPM outputs is easily accomplished

EIM Series 2000 electric motors are multi-rated and O-ring sealed for NEMA 4 (Water-tight and dust-tight), NEMA 6 (temporary submergence), and NEMA 7 (explosionproof) Series 2000 motors employ a minimum number of mounting configurations for maximum interchangeability. The motor and spur gear set form a modular unit, mounting to the actuator with only eight easily accessible fasteners.

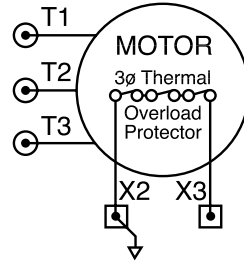

Thermal Overload Protection

- Standard motors are supplied with thermal overload protection (may be disabled for emergency shut-down installations)
- Thermal contacts sense the winding temperature and break the control circuit before damage can be done

# CLUTCH

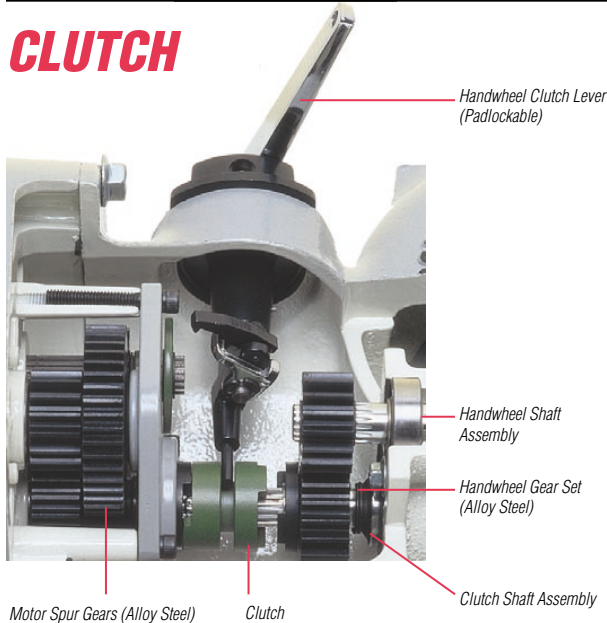

Clutch Lever Assembly

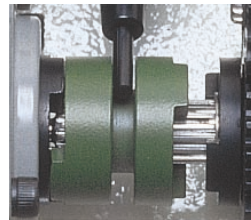

Clutch Spool

- Clutch lever assembly shifts the position of splined clutch spool so that power drive engagement is either by motor or handwheel
- Requires no adjustment and mounts with three screws for ease of maintenance

- The patented EIM clutch spool device makes simultaneous engagement of motor and handwheel impossible
- Power from the motor cannot be transmitted to manual handwheel
- Drive connection to the worm shaft is by sliding spline

The EIM Series 2000 Electric Actuator includes an auxiliary handwheel for emergency use. Selection of the handwheel mode of operation is by external clutch lever on the low torque side of the worm and worm gear drive train. Type EB03 and EB04 do not have an external lever.



Padlockable Clutch Lever

- Although clutch is motor-preference, the clutch lever may be padlocked in the "manual" mode for safe maintenance, or in the "motor" mode to protect against unauthorized use
- Without padlock, the Series 2000 will automatically shift to the "motor" mode when the motor is energized



## MAIN DRIVE GEARS

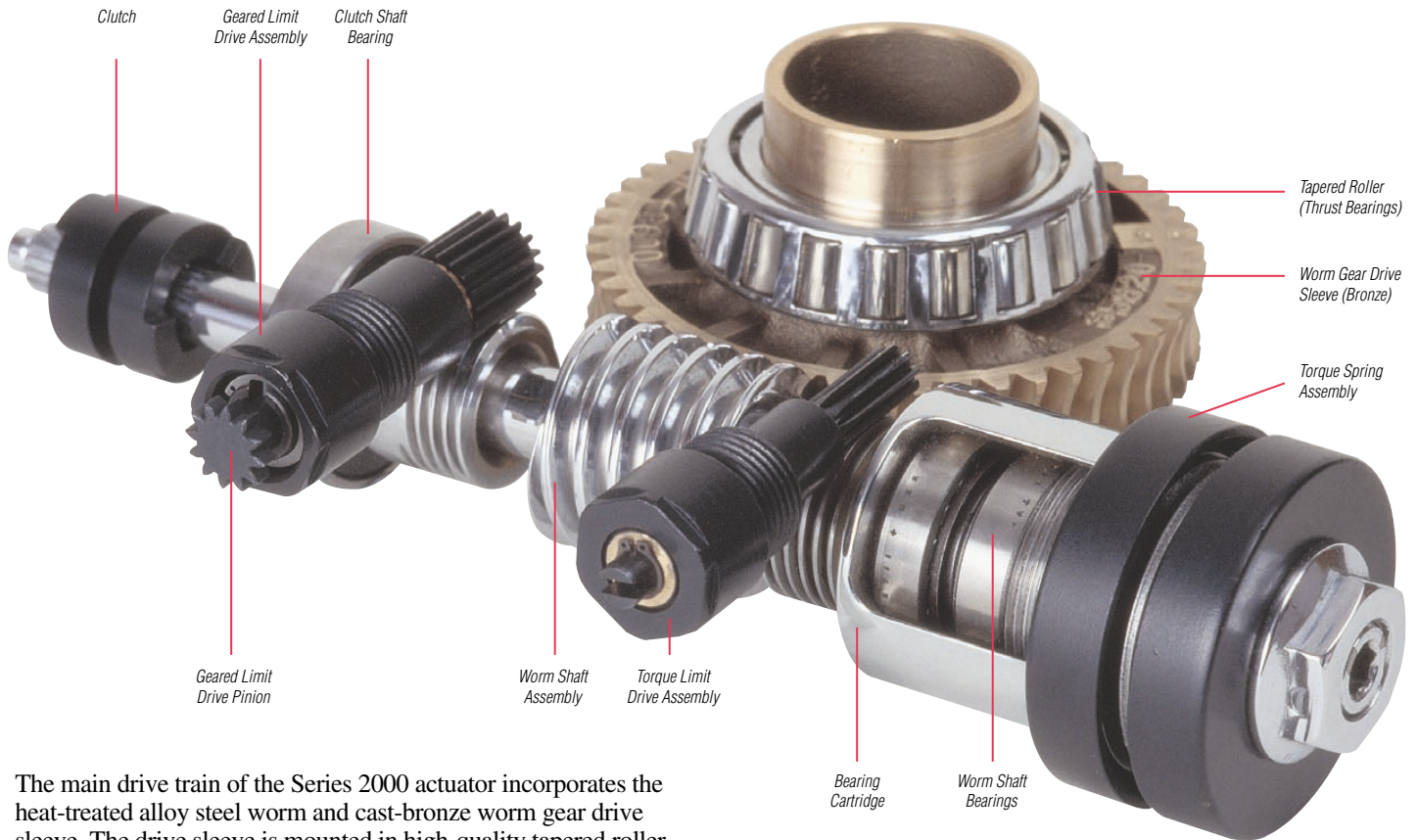

The main drive train of the Series 2000 actuator incorporates the heat-treated alloy steel worm and cast-bronze worm gear drive sleeve. The drive sleeve is mounted in high-quality tapered roller bearings for maximum thrust load support.

- Torque is received through the clutch shaft from the motor and first-stage motor spur gear set
- Torque springs are easily accessible for field replacement for higher or lower torque range
- The alloy steel heat-treated worm is mounted in tapered roller bearing supports



*Worm and Clutch Assembly*

- In operation, the clutch shaft is "fixed" by splined connection to insure accurate geared limit drive calibration
- The worm moves axially on its splined connection in either direction against the torque spring assembly for torque sensing
- Input from the motor and motor gears is transmitted through the worm to the bronze drive sleeve



*Clutch Shaft Splined Connection*

- Quarter Turn Actuators offer a bottom-entry splined steel bushing design which simplifies assembly to the valve
- Splines provide a high strength multiple position connection to the keyed valve shaft, improving the accuracy of seat calibration and allowing for multiple mounting positions not possible with bored and keyed drive sleeve
- Cast bronze worm gear drive sleeve is mounted in high quality tapered roller bearings for maximum thrust load support

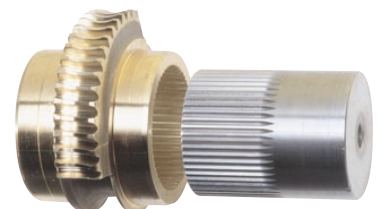

*Splined Drive Bushing*

# TORQUE LIMIT & GEARED LIMIT DRIVE ASSEMBLIES

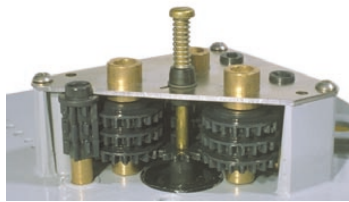
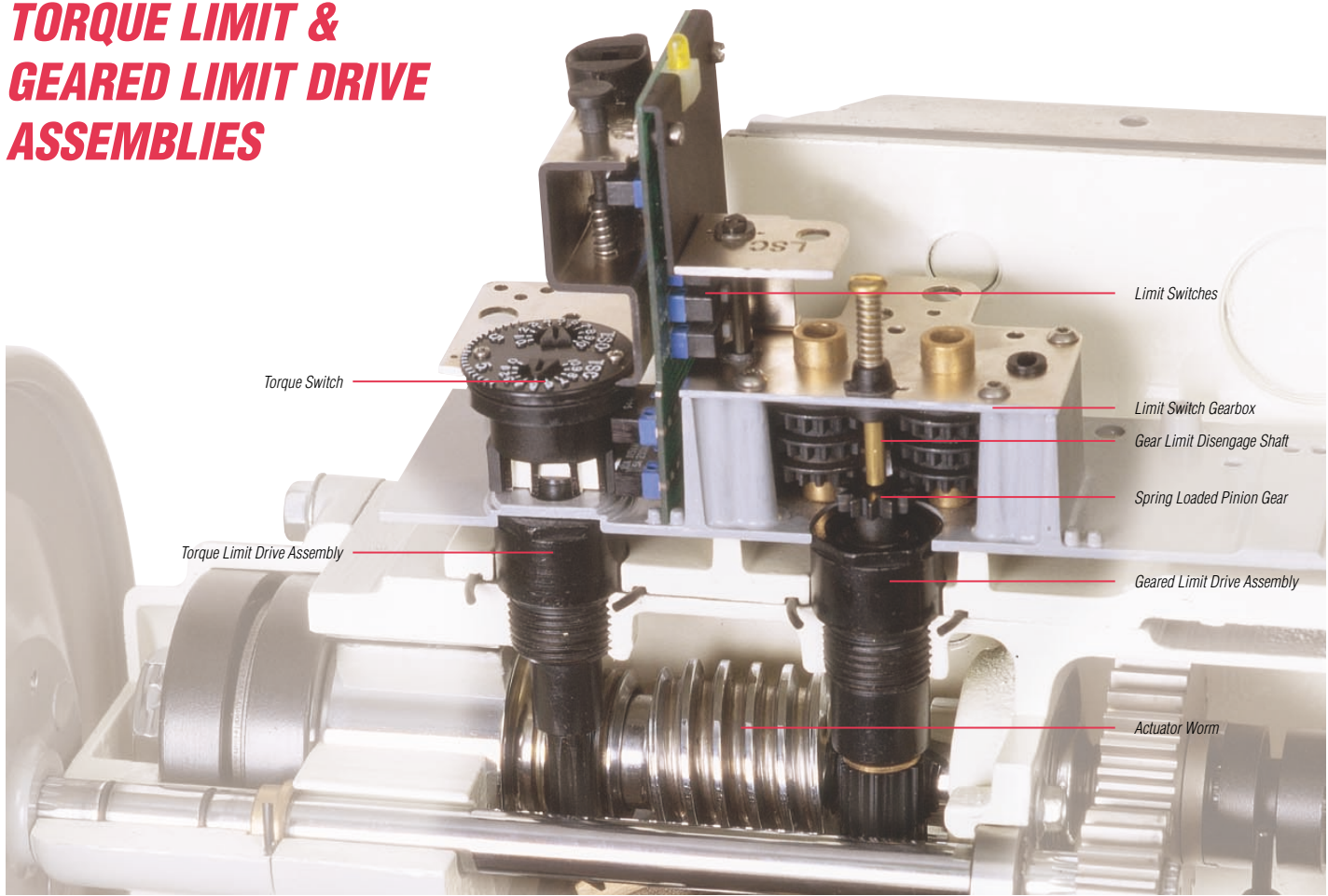

Limit Switch Gear Box

- Limit switch gear box is mechanically connected to actuator worm through the geared limit drive assembly
- This mechanical sensing device remains in-step with the valve position at all times, whether driven by motor or handwheel, even under lost power conditions
- Both the torque switches and the limit switches will maintain their settings in all conditions without relying on battery backups

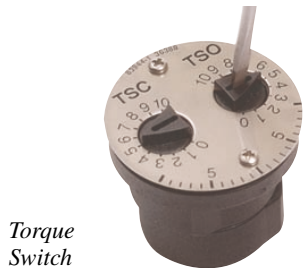

Torque Switch

- Torque switch adjustment determines the amount of movement permitted before the motor reversing starter is de-energized
- Independent adjustment of open and closed torque switches permits setting a different torque to the valve stem for each direction
- Pin stops are located beneath the switch indicator cover. Moving the pin from the factory set position (10) to any desired position (1-9) limits the adjustment that can be dialed into the torque limit switch

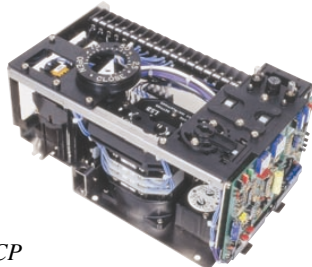

MCP

- The MCP (Modular Control Package) has been proven in service for over 20 years
- The MCP will continue to be available for parts, integration into existing environments, and applications where hardwiring is desirable

# M2CP MODULAR CONTROL PACKAGE

EIM's M2CP modular control package has been specifically designed to provide users a highly flexible, reliable, and competitively priced control system for electric valve automation. Through its unique design concept, servicing and upgrading can easily be accommodated. The entire package or any of its components can be removed and replaced within minutes. All components have been carefully selected to provide years of trouble free service. The M2CP is the highest quality, most flexible, and accommodating actuator control concept available.

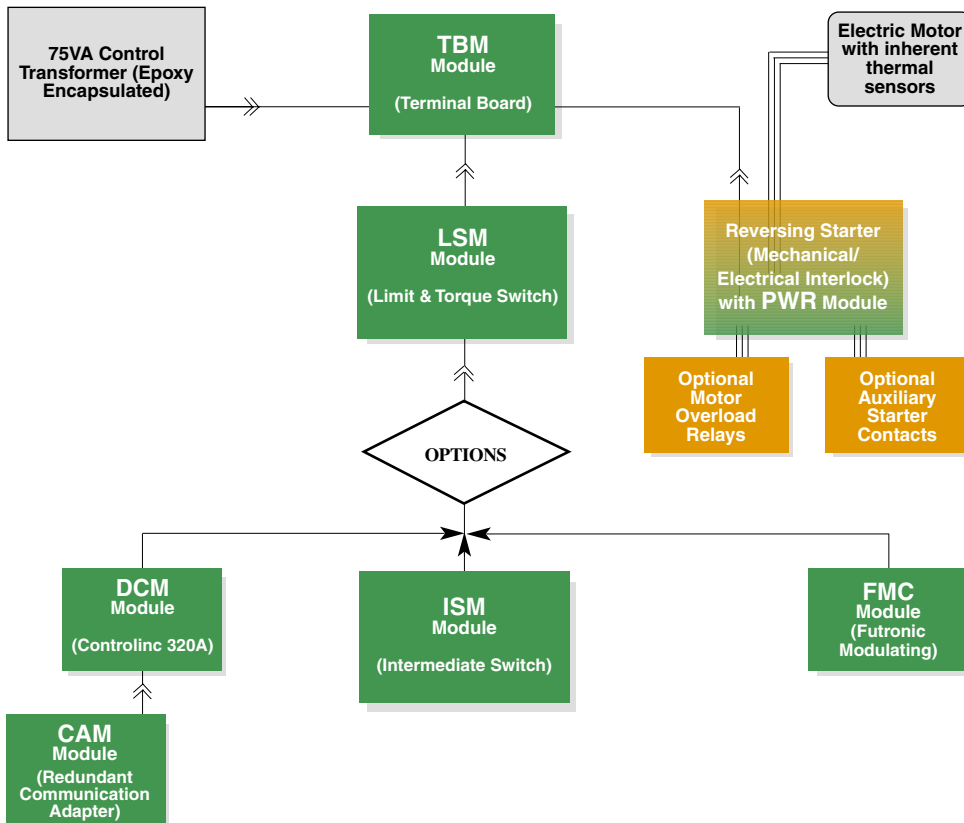
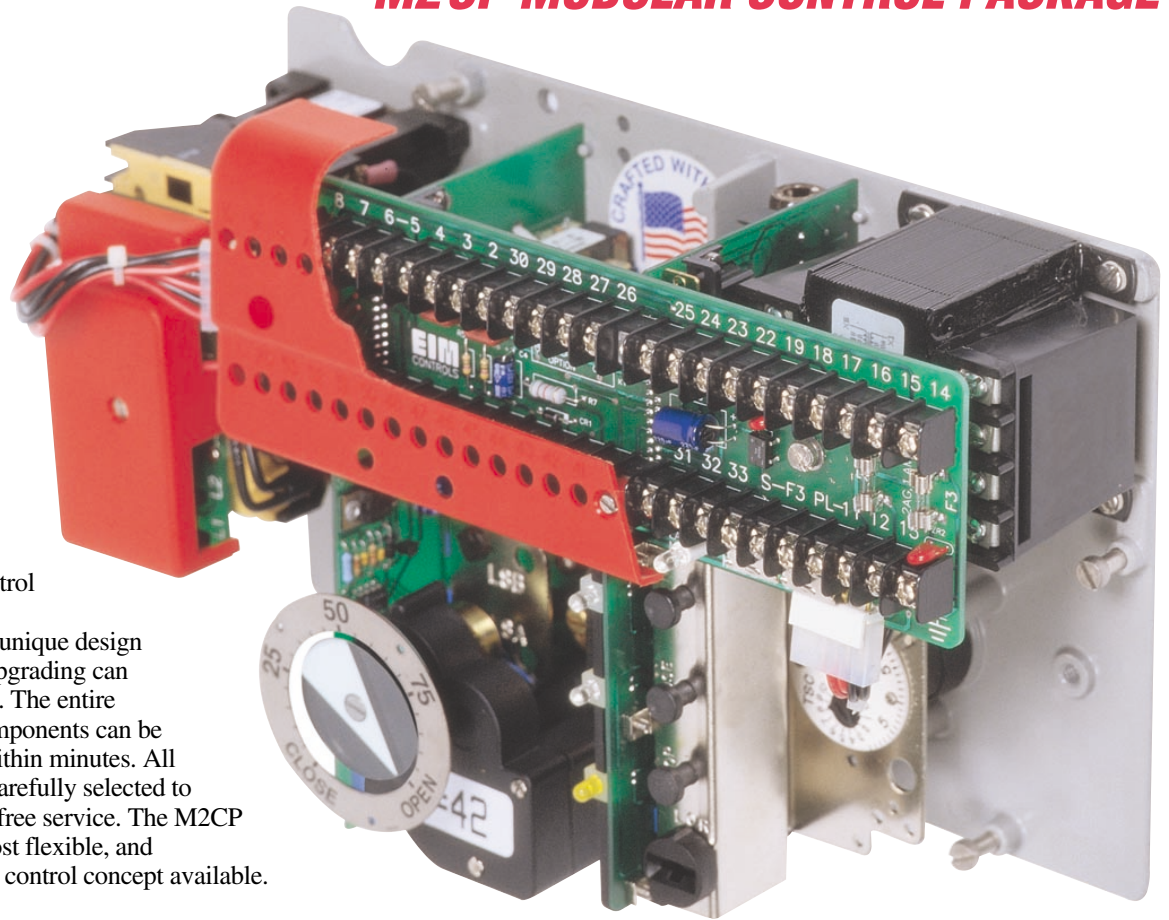

## TBM (Terminal Board Module)

- 48 Point Terminal Block
- Dual Secondary Transformer Fuses
- Snubber Circuit (Transient Voltage)
- 4<sup>th</sup> Pilot Light, Programmable
- 12VDC Internal Supply
- Monitor Relay Option

## LSM (Limit Switch Module)

- Open/Close Limit Switch (3-NO/3-NC Contact/Direction)
- Open/Close Torque Switch (1-NO/1-NC Contact/Direction)
- 3 Pushbuttons (Open-Stop-Close)
- 3 LED Pilot Lights (Open-Close-Power On)
- 3-Position Selector Switch (Local-Off-Remote)
- 25 Watt Space Heater

## PWR (Power Module)

- 5 Point Power Block Dual
- Primary Transformer Fuses

## ISM (Intermediate Switch Module)

- Intermediate Limit Switch (2-NO/2-NC Contacts)
- Potentiometer/s Options
- 4-20mA Feedback Signal
- Interposing Relay Options

## FMC (Futronic Modulating Control)

- Position Control
  - Futronic II (A.C. Motor)
- Process Control
  - Futronic III (D.C. Motor)
  - Futronic VIII (Variable Frequency Drive)

## DCM (Digital Control Module)

- Controlinec 320A (Block Valve & Process Control)

## CAM (Communication Adapter Module)

- Redundant Communication Channels



## M2CP OPTIONS & ACCESSORIES



The stainless remote pushbutton station can be close-coupled to the actuator or remotely mounted. It is available in several configurations including combinations of circuit breaker, disconnect switch, or lights, pushbuttons, and selector switch.



- Mechanical Dial Position Indicator is visible through an explosion proof window in the switch compartment cover
- Indicator is driven by the high precision set of reduction gears and on multi-turn applications the MDPI provides visual indication of valve position from 0 - 100%
- Dial is mechanically in-step with valve position at all times regardless of motor or hand wheel operation and availability of power



MDPI

- Circuit Breaker/Disconnect Switch interrupts the circuit between the actuator and the current source to insure safety during field maintenance and repair
- EIM has several disconnect devices available mounted in electrical compartment or in separate control modules which can be close-couple-connected to actuator or bracket-mounted to a wall, panel, rack, or pipe
- External door interlocks require disconnect to be engaged before opening electrical compartment cover

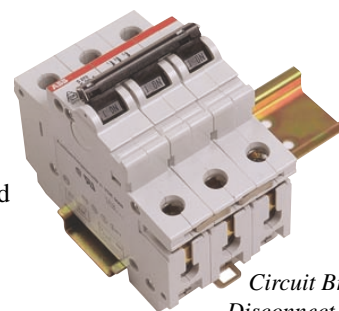

Circuit Breaker/  
Disconnect Switch

- The Futronic line is EIM's family of modulating controls capable of handling both position and process control via industry standard 4-20 mA signal
- Futronic II - Position Control - 1 or 3 Phase power
- Futronic III - Process Control - 1 Phase power
- Futronic VIII - Process Control - Variable Frequency - 3 Phase

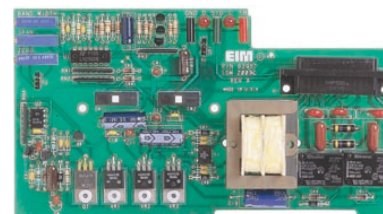

Futronic II

# CONTROLINC® NETWORK CONTROL

Valve actuators have undergone major changes during the past fifty years. What started out as a "muscle machine", capable only of opening and closing valves in response to a manual switch, has evolved into an intelligent "brain machine" that handles both traditional open/close (block) as well as precise setpoint (modulating) commands, all over a dedicated digital highway. Understanding this evolution will help the Customer understand today's systems and their benefits.

Controlinc® is EIM's revolutionary digital control system, utilizing onboard microprocessors located in every Controlinc® equipped actuator for control and monitoring of multiple valve actuators.

EIM was the pioneer in using digital control for valve actuators. The first model was introduced in 1985 in response to market requirements for Smart valve actuator control via a twisted pair Local Area Network (LAN). Since 1985, many enhancements have been incorporated as technology evolved. More powerful microprocessors, PC board surface mount technology and emerging software technologies have resulted in the most advanced digital valve controller on the market today.

Controlinc® allows a single Host system to control hundreds of valves across a single twisted pair of wire. Simple two-wire networking means fast, reliable and economical operation. And since Controlinc® can be installed in any EIM Series 2000 electric valve actuator, you can easily upgrade an existing system.

## Standard Controlinc® 320A Features and Benefits:

- Microprocessor based controller integral to each valve actuator.
- Suitable for use with all types of valves and most processes.
- Removal or failure of the module does not affect local pushbutton control.  
*No other Manufacturer has this ability.*
- Simple installation and setup.
- Easy to use and maintain.
- No proprietary protocols used. All communication occurs via industry standard **Modbus RTU** protocol. This enables the Host to communicate directly to each actuator or to EIM's optional Network Master.
- Backwards compatibility for over 20 years of product.
- Reduces central computing equipment costs.
- Learns characteristics of the valve and adapts itself.
- Auto-calibration eliminates user adjustments.
- Reduces wiring costs up to 60%
- Reduces setup/startup costs 50-90%
- Capable of data acquisition and control of other devices at no additional cost.
- Compatibility with existing Host equipment (PLC, DCS, SCADA).
- Real time data, diagnostics & alarms limit down time, hazards, process upsets and losses.
- Single model reduces spare parts inventory.

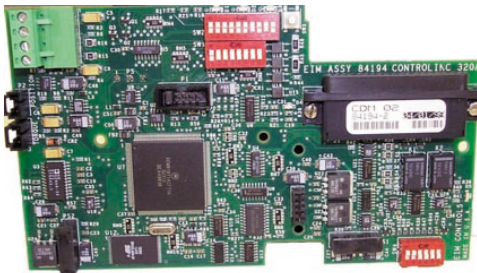

Controlinc 320A  
Digital Control Module (DCM)

## Network Master Features and Benefits:

- Provides network management and data concentration, thereby offloading these tasks from the Host. This enhances overall system performance and minimizes software development and configuration tasks that would be required by the System Integrator.
- Manages the network by keeping an orderly cycle of data transfers to and from the connected actuators.
- Data concentration for the Host is achieved by providing a common database for all actuators. The Host need only to communicate with one slave device (network master) for all data transfers to and from the field.
- Provides isolation and transient protection for Host.
- Input cabling from Host can be RS-232, -485 or -422.
- 19" rack or desktop mountable.
- Supports baud rates up to 115,200 baud.
- Optional LCD display/keypad allows user to control the network and receive status and alarms of each actuator on the network.
- Supports up to 254 actuators.



Controlinc Network Master  
with optional LCD display

# THE ULTIMATE NETWORK CONTROL SYSTEM

## USER BENEFITS

*Affordable* - greatly reduced cable costs.

*Reliable* - able to maintain local pushbutton control in event of field unit removal or electronic component failure.

*Economical* - distributed processing off-loads the host system, reducing the need to increase capacity.

*Dependable* - full system redundancy capable of withstanding multiple line breaks.

*Flexible* - plug-in adapters support various network topologies (including single and redundant bus and ring networks, RS-232, RS-485, or the Controlinc 22,000-foot parallel bus network).

*Expandable* - up to 254 devices per network.

*Accurate* - mechanical geared limit and torque switches maintain valve and actuator position in power failure.

*Standards based* - Modbus RTU communications.

*Performance* - capable of operating at 19.2 baud with 254 stations over 200 miles.

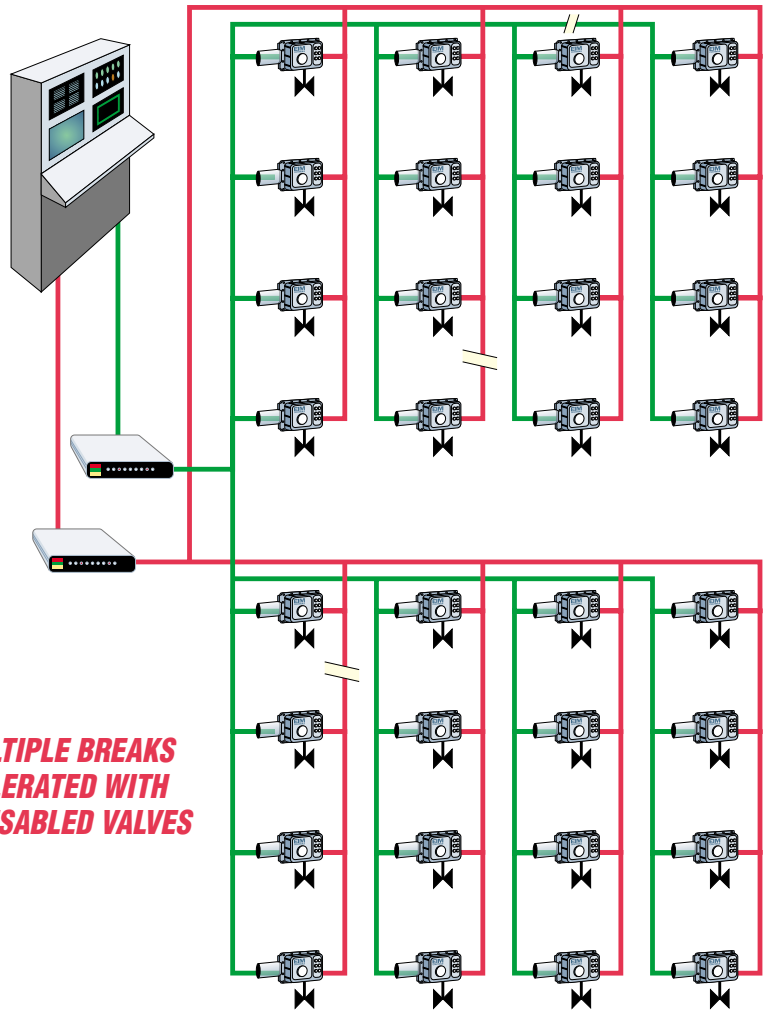

**MULTIPLE BREAKS TOLERATED WITH NO DISABLED VALVES**

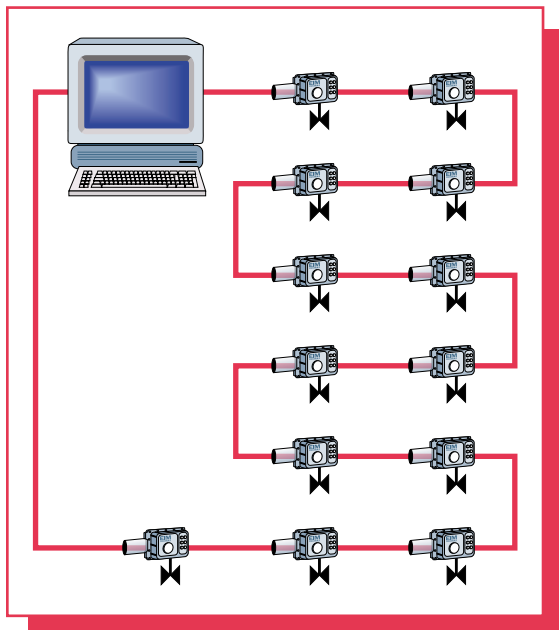

*RS-485 E>NET network supports up to 254 devices over a 200 mile range*

*CONTROLINC 22,000-foot redundant bus network supports up to 254 devices*

For more information, see the **Controlinc 320A Brochure**



**Manufacturing** - Employing the latest technology, the finest materials, and a consistent focus on quality, all EIM products are built to be the very best.



**Assembly** - EIM's mechanical and electrical assembly departments are coordinated by the MRP/II system, allowing EIM to be responsive to even the most critical delivery requests.



**Quality Assurance** standards are strictly followed at every stage of the manufacturing process, from receipt of materials to component machining to final assembly.



**On-time Delivery** - EIM prides itself on retaining industry leadership in on-time delivery by continuing to hold customer satisfaction as goal #1.

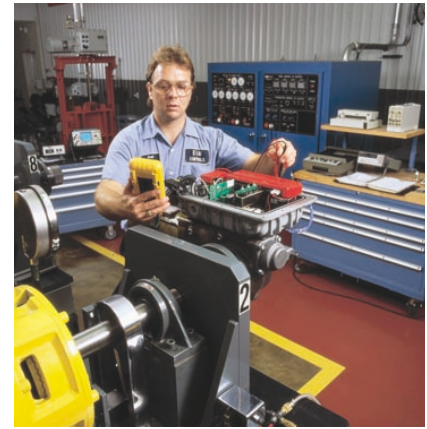

**Test Lab** - A complete range of dynamometers, thrust stands, and variable electrical power permits EIM to load test any actuator at any electrical supply. All published ratings have test lab certification.



**Training** - EIM offers training programs focusing on valve actuator application as well as hands-on experience. These factory and on-site programs are tailored to meet the specific needs of the customer.



**Field Service** is provided by an extensive network of EIM service personnel and trained and certified distributors. All factory or on-site service is performed with factory approved EIM parts.

A Total Commitment to Quality, Technology, Performance and Customer Support for:

■ POWER ■ WATER TREATMENT ■ INDUSTRIAL ■ MARINE ■ PIPELINE ■ PETROCHEMICAL

**EIM CONTROLS**  
13840 Pike Road  
Missouri City, Texas 77489

1-800-679-1561  
Ph: (281) 499-1561 • FAX: (281) 499-8445



www.eim-co.com



**LYNSA**  
Medición y Control  
Industrial

E-Mail: [ventas@lynsa.com](mailto:ventas@lynsa.com)  
Web : [www.lynsa.com](http://www.lynsa.com)